

AMTHY

<https://amthy.com>

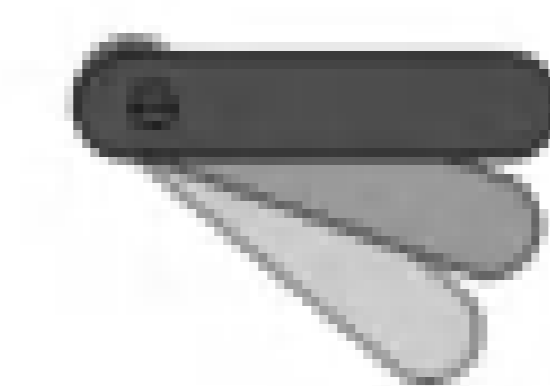

CONCEALED.
HINGE

INVISIBLE AND BOUNDLESS



无形无境



CONTENTS

HYDRAULIC DUMPLING CHAIN



P.08

Ecological door supporting series:
Minimalist, functional, unique shape,
beautiful appearance and exquisite
workmanship.

3D ADJUSTABLE HINGE



P.12

Ecological door supporting series:
Minimalist, functional, unique shape,
beautiful appearance and exquisite
workmanship.

HYDRAULIC HINGE

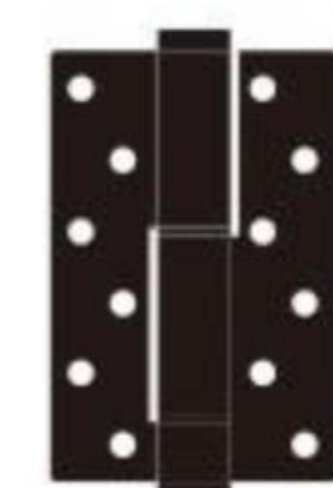

P.26

Ecological door supporting series:
Minimalist, functional, unique shape,
beautiful appearance and exquisite
workmanship.

ECO DOOR LOCK



P.30

Ecological door supporting series:
Minimalist, functional, unique shape,
beautiful appearance and exquisite
workmanship.

WINDPROOF DOOR SUCTION



P.36

Ecological door supporting series:
Minimalist, functional, unique shape,
beautiful appearance and exquisite
workmanship.

SUCK STEALTHILY

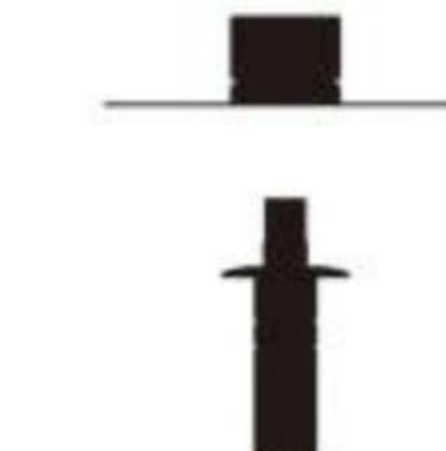

P.45

Ecological door supporting series:
Minimalist, functional, unique shape,
beautiful appearance and exquisite
workmanship.

FINISH OPTIONS



01 (亮铬)
Polished chrome



02 (砂铬)
Sha Guangyao



03 (枪黑单色)
Gun Black Monochrome



04 (哑黑/曜石黑)
Matte black



05 (真金)
PVD real gold



06 (棕古铜拉丝)
Zong bronze brushed



07 (消光铜拉丝)
Copper wire drawing



08 (哑光镍拉丝)
Brushed nickel



09 (哑光黑拉丝)
Black brushed



10 (镍单色)
Nickel monochrome



11 (K金)
K gold



12 (砂金)
Alluvial gold



13 (砂银)
Sand silver



14 (铁灰)
Dark grey

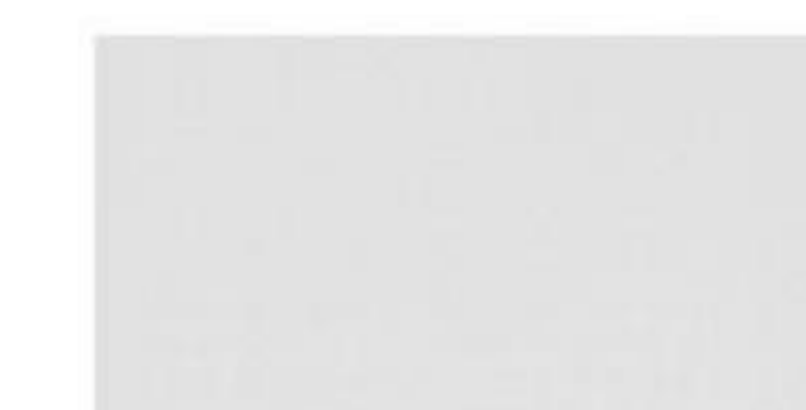

15 (白色)
White

暗藏液压铰链

SL01



Finish Options
可选表面处理

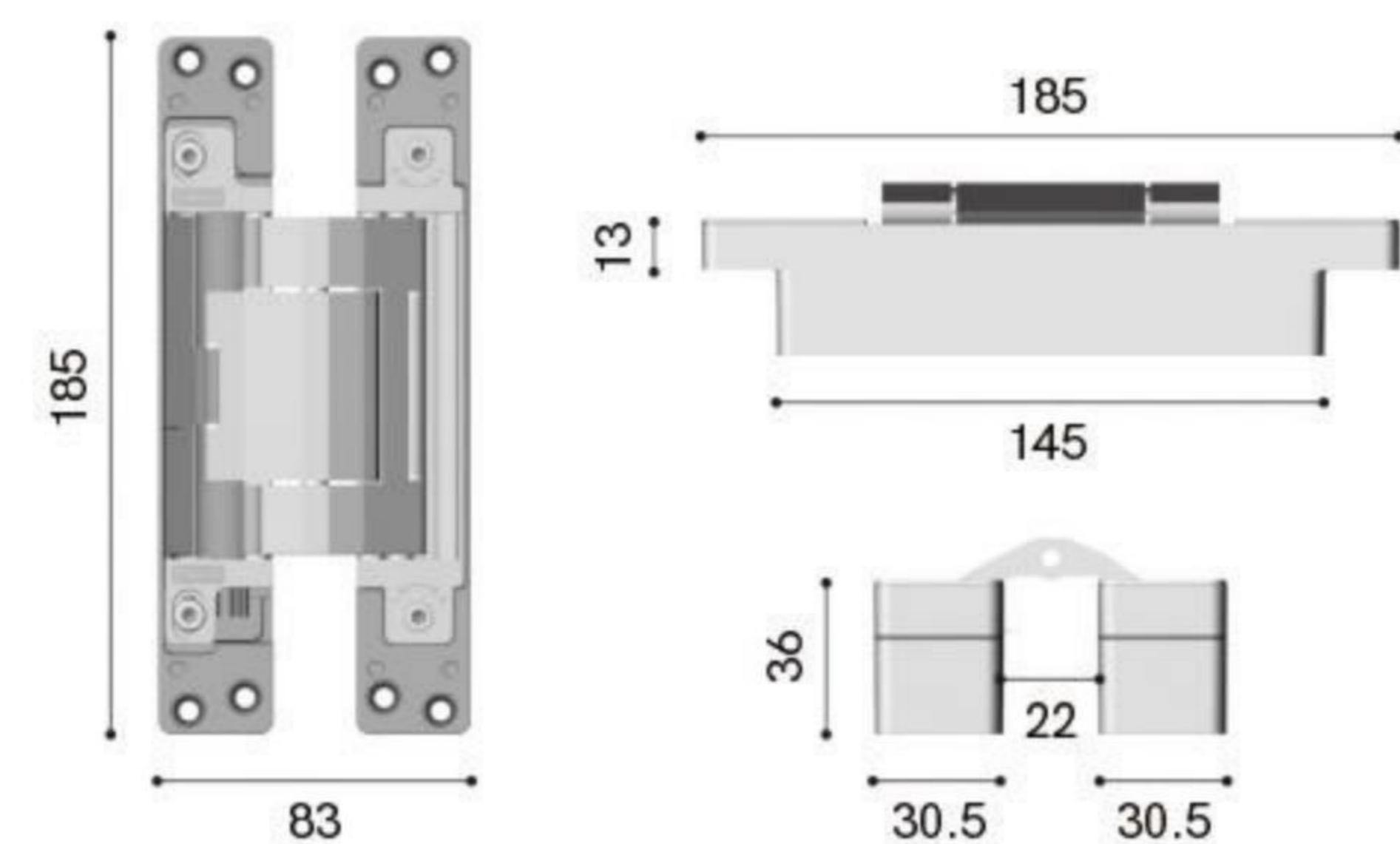
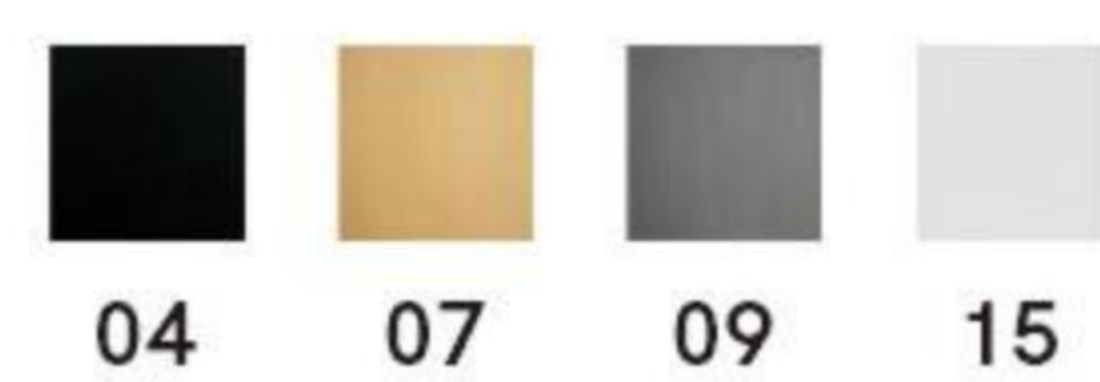

自动关门
省心省力

暗藏可调 液压铰链

HIDDEN ADJUSTABLE
HYDRAULIC HINGE



暗藏液压铰链

SL01

功能示意图

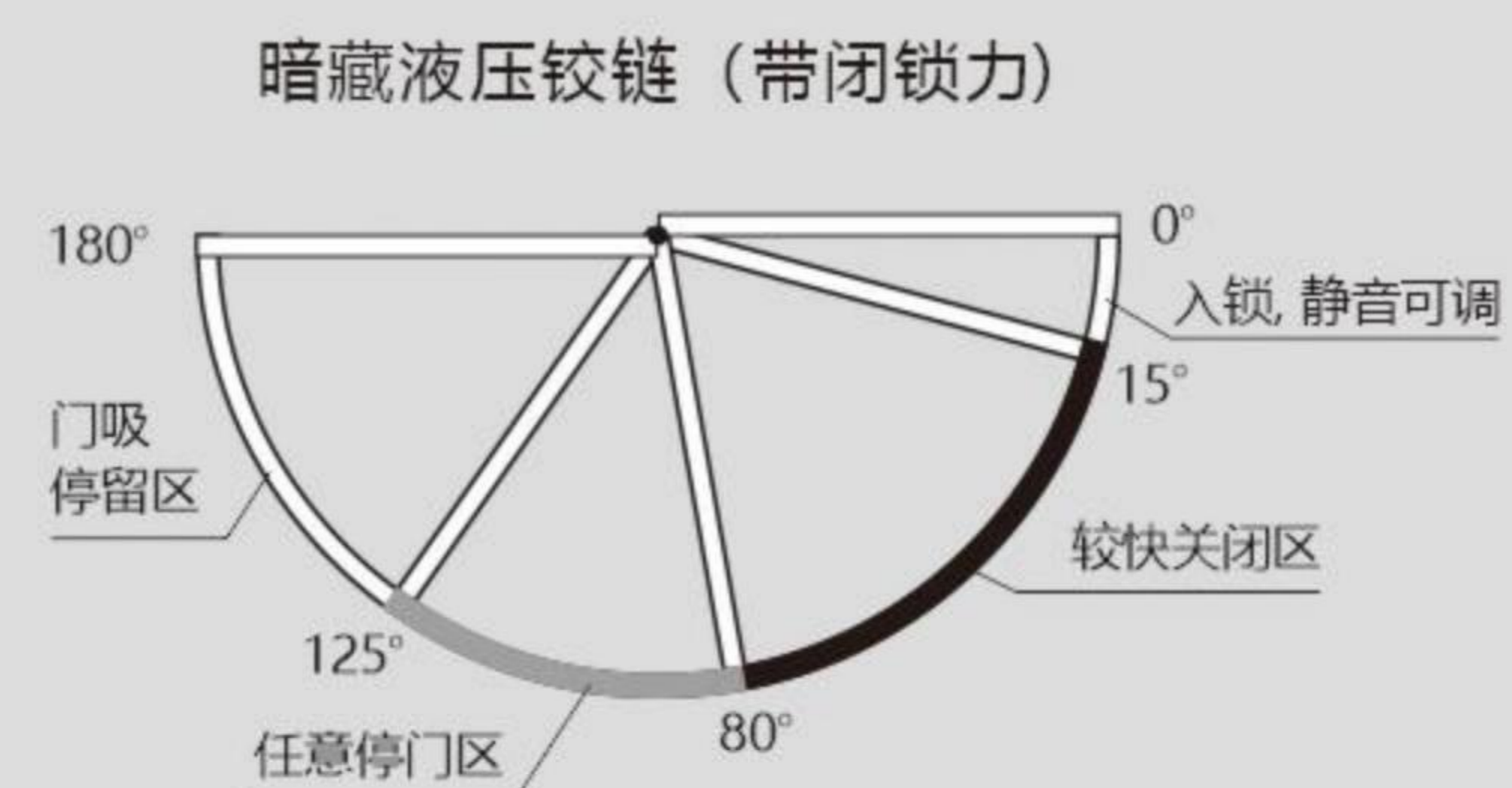

使用注意事项

- 本产品不能用在直接接触雨雪的场所。依据使用闭门器的不同可能会使合页破损或者动作异常从而导致门无法关紧，请使用前请务必先确认。
- 门上的合页出现往下掉时不要大力关门，会造成合页的破损。
- 门有翘曲或变形时合页可能动作变差造成门无法关紧。
- 使用中要定时确认各部位螺丝有无松动。

性能及参数

- 主体材质: 锌合金。
- 二维可调: 左右±2.0mm 上下±2.5mm
- 最大开启角度: 180°
- 定位停门: 85°—125°自由停门
- 单只闭门力: 6N.m。
- 适用温度范围: -5°C - 45°C。
- 使用寿命: ≥20万次

合页配备	最大承重	门外形尺寸	表面颜色
2只液压	60kg	门厚≥42mm 门高≤2000mm 门宽≤800mm	曜石黑 镍单色
1只承重 2只液压	80kg	门厚≥45mm 门高≤2200mm 门宽≤900mm	
3只液压	100kg	门厚≥50mm 门高≤2400mm 门宽≤950mm	

Finish Options
可选表面处理

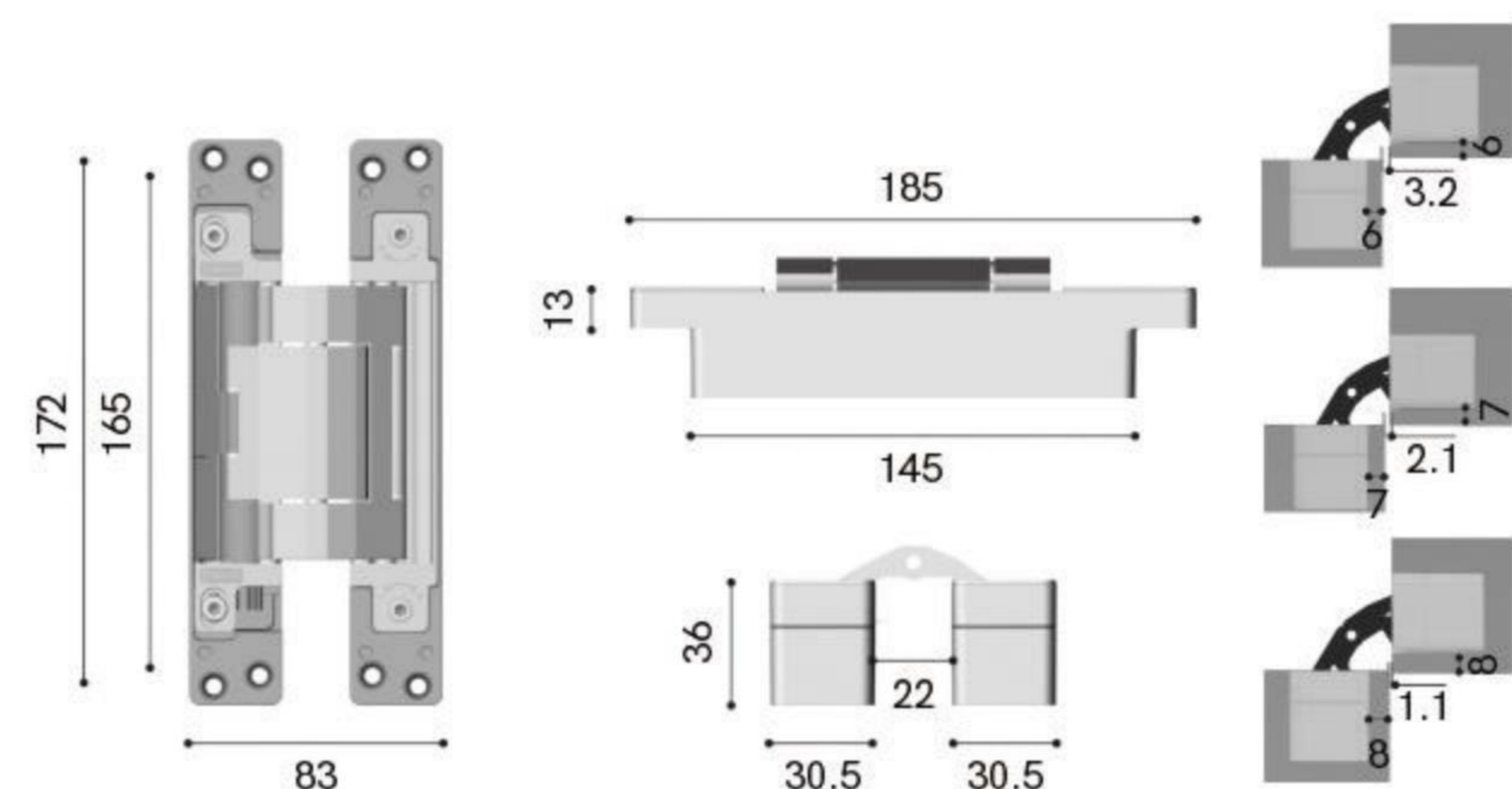
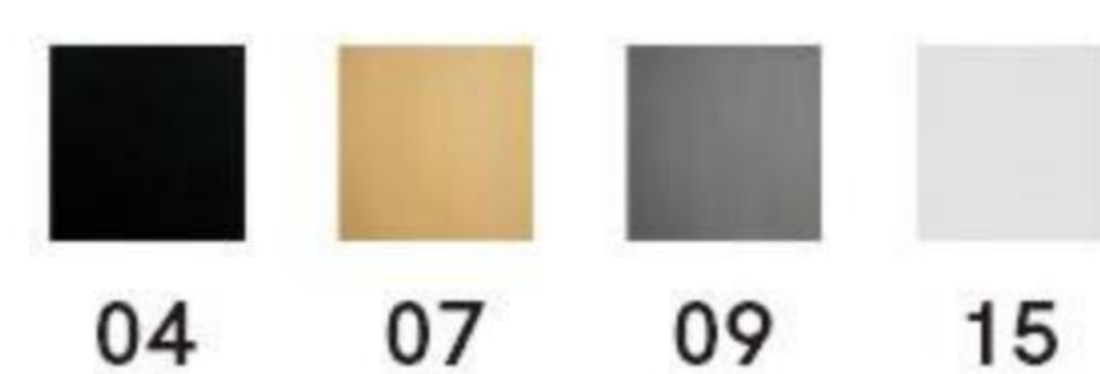

暗藏可调
液压铰链

HIDDEN ADJUSTABLE
HYDRAULIC HINGE



暗藏液压铰链

SL05

功能示意图

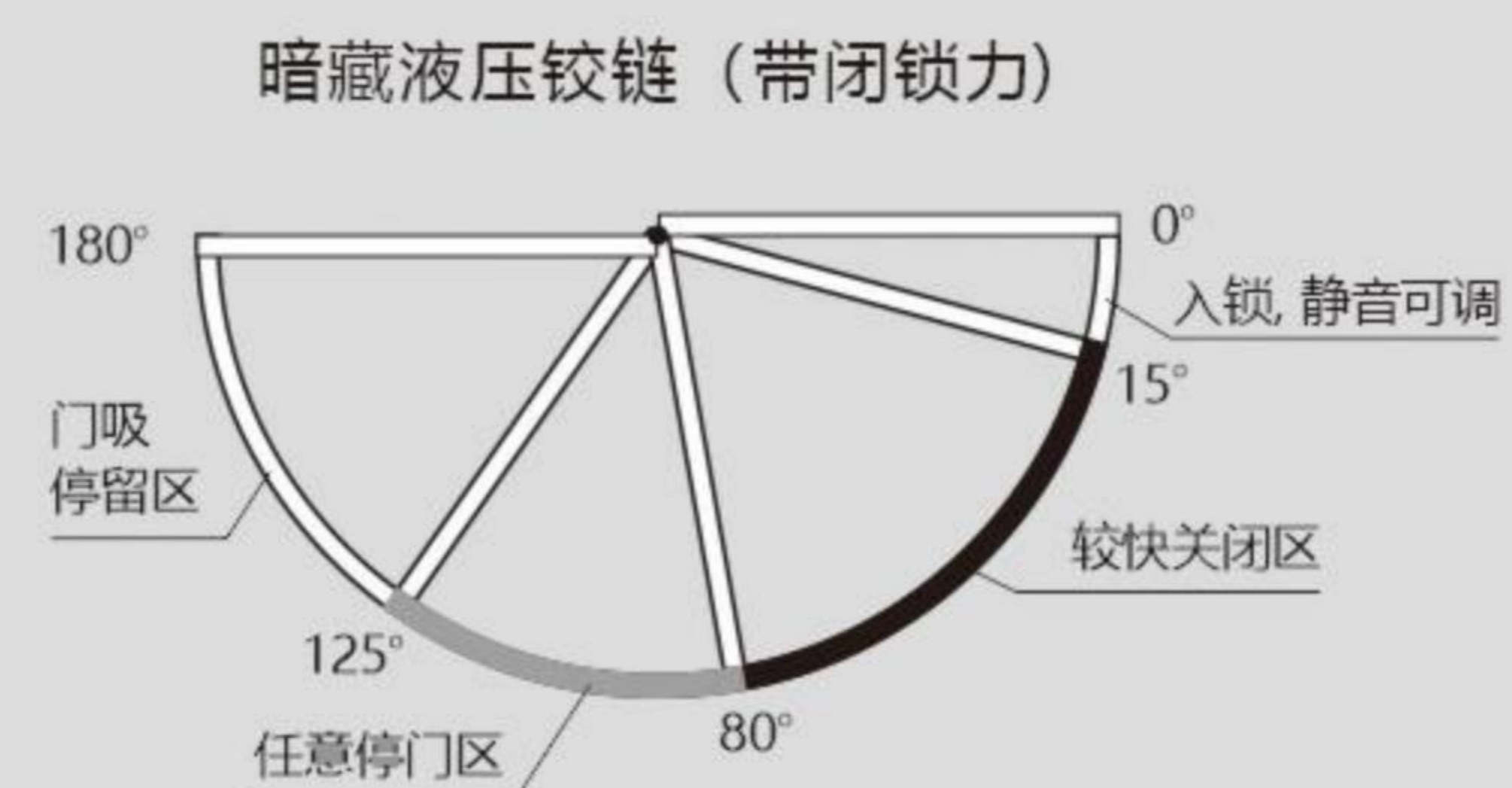

使用注意事项

- 本产品不能用在直接接触雨雪的场所。依据使用闭门器的不同可能会使合页被损或者动作异常从而导致门无法关紧, 请使用前请务必先确认。
- 门上的合页出现往下掉时不要大力关门, 会造成合页的破损。
- 门有翘曲或变形时合页可能动作变差造成门无法关紧。
- 使用中要定时确认各部位螺丝有无松动。

性能及参数

- 主体材质: 锌合金。
- 二维可调: 左右±2.0mm 上下±2.5mm
- 最大开启角度: 180°
- 定位停门: 85°—125°自由停门
- 单只闭门力: 6N.m。
- 适用温度范围: -5°C - 45°C。
- 使用寿命: ≥20万次

合页配备	最大承重	门外形尺寸	表面颜色
2只液压	60kg	门厚≥42mm 门高≤2000mm 门宽≤800mm	曜石黑 镍单色
1只承重 2只液压	80kg	门厚≥45mm 门高≤2200mm 门宽≤900mm	
3只液压	100kg	门厚≥50mm 门高≤2400mm 门宽≤950mm	

Finish Options
可选表面处理

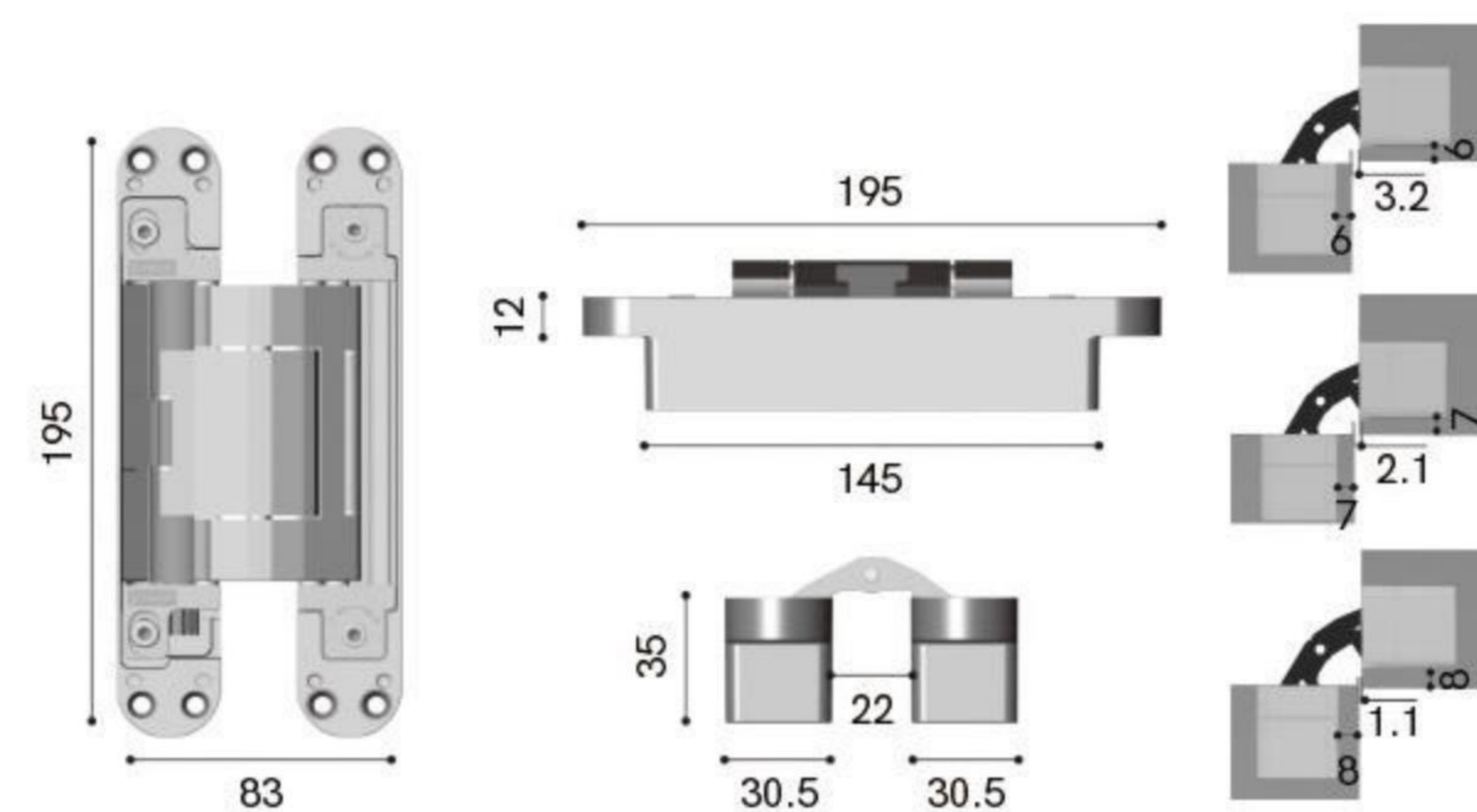
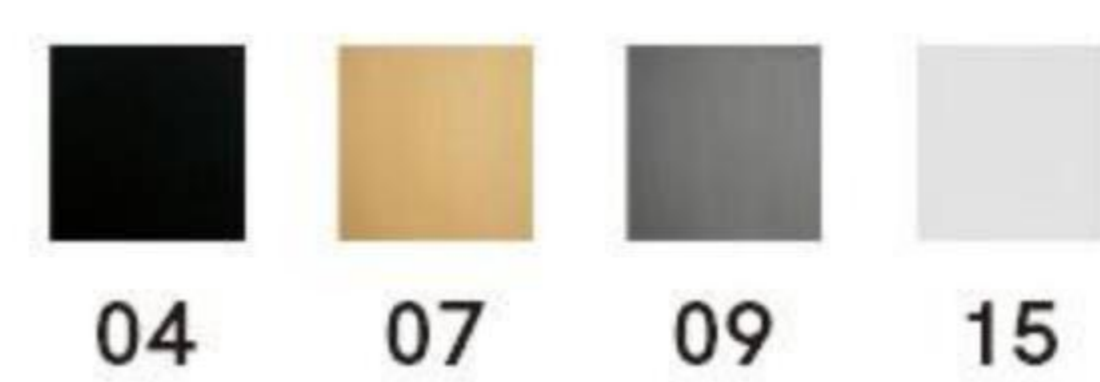

双动力暗藏液压铰链

SL06



Finish Options
可选表面处理

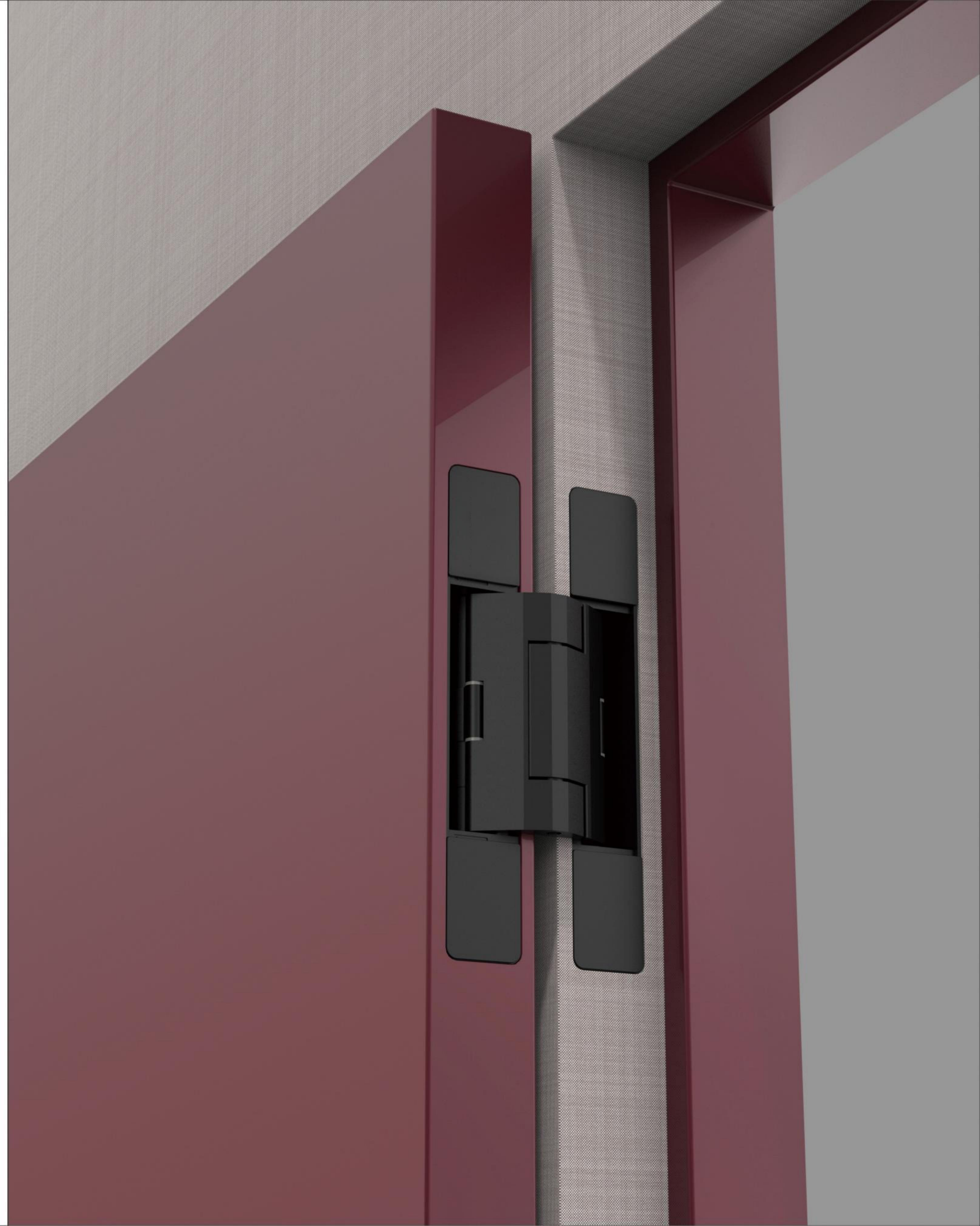
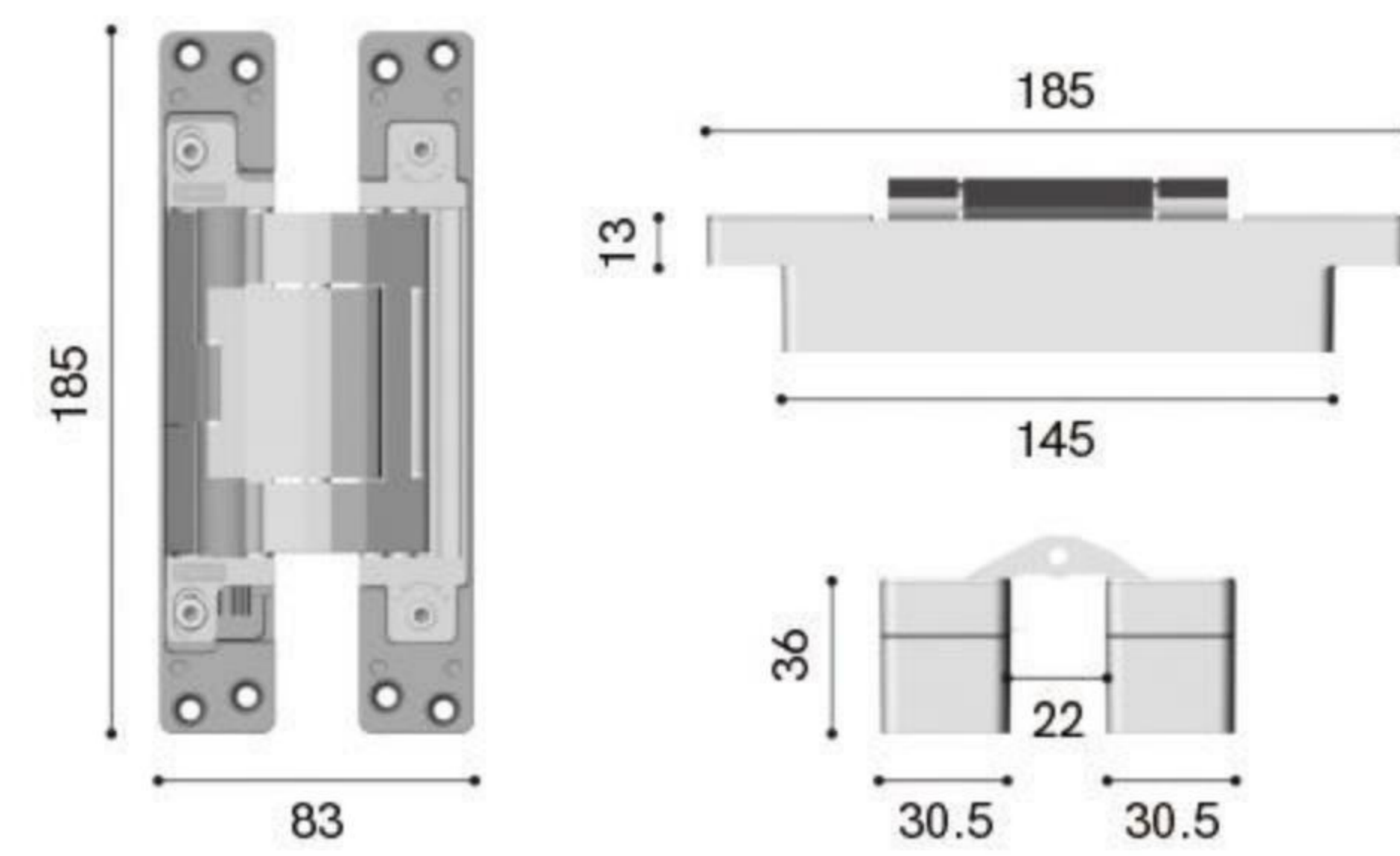

双动力暗藏液压铰链

SL06

功能示意图

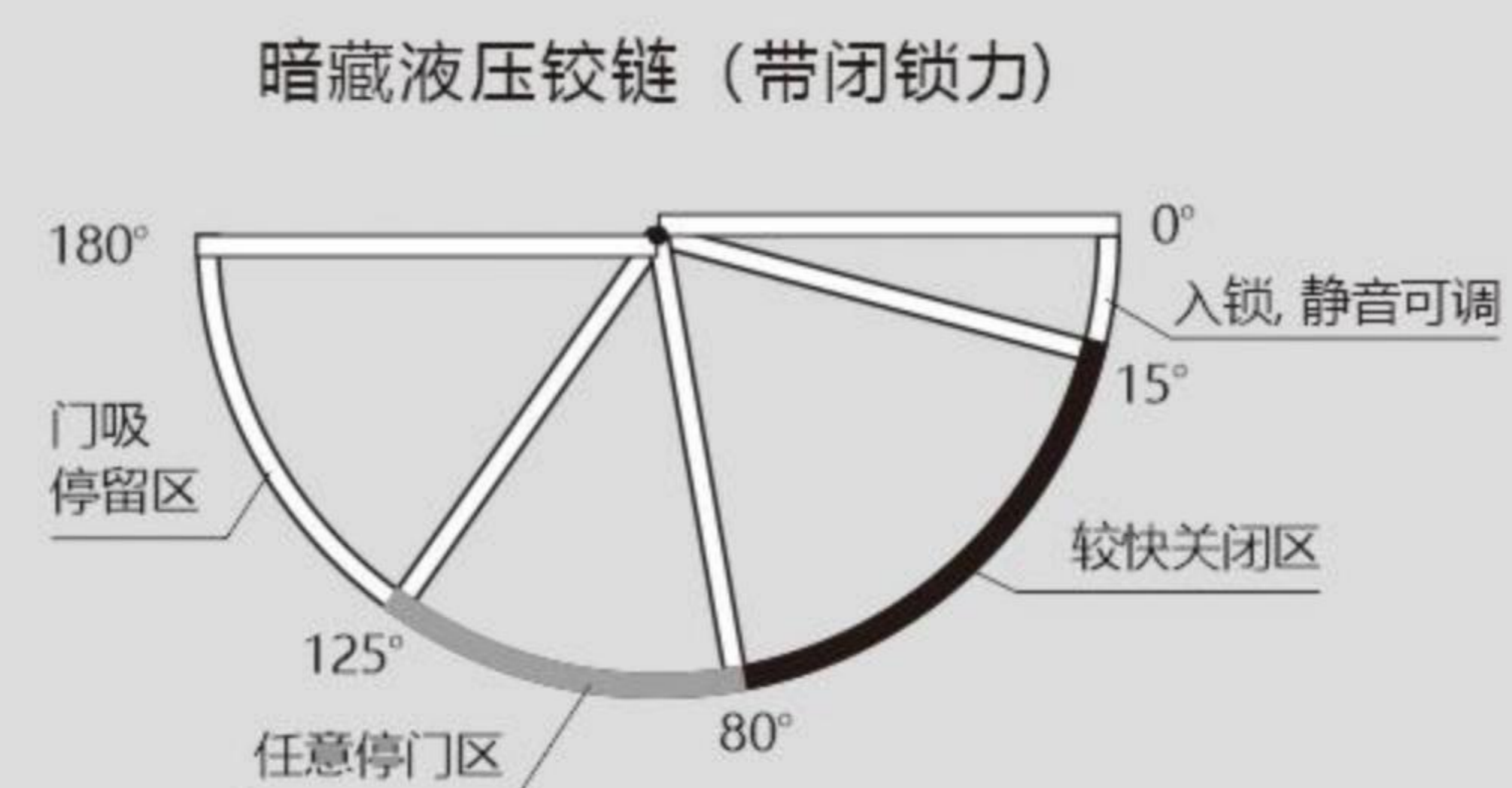

使用注意事项

- 本产品不能用在直接接触雨雪的场所。依据使用闭门器的不同可能会使合页被损或者动作异常从而导致门无法关紧，请使用前请务必先确认。
- 门上的合页出现往下掉时不要大力关门，会造成合页的破损。
- 门有翘曲或变形时合页可能动作变差造成门无法关紧。
- 使用中要定时确认各部位螺丝有无松动。

性能及参数

- 主体材质: 锌合金。
- 二维可调: 左右 $\pm 2.0\text{mm}$ 上下 $\pm 2.5\text{mm}$
- 最大开启角度: 180°
- 定位停门: $68^\circ - 125^\circ$ 自由停门
- 单只闭门力: 11N.m 。
- 适用温度范围: $-5^\circ\text{C} - 45^\circ\text{C}$ 。
- 使用寿命: ≥ 20 万次

合页配备	最大承重	门外形尺寸	表面颜色
2只液压	80kg	门厚 $\geq 50\text{mm}$ 门高 $\leq 2800\text{mm}$ 门宽 $\leq 850\text{mm}$	04 哑黑/曜石黑 07 消光铜拉丝 09 哑光黑拉丝 15 白色
1只承重 2只液压	100kg	门厚 $\geq 55\text{mm}$ 门高 $\leq 3000\text{mm}$ 门宽 $\leq 900\text{mm}$	
3只液压	120kg	门厚 $\geq 60\text{mm}$ 门高 $\leq 3000\text{mm}$ 门宽 $\leq 950\text{mm}$	

Finish Options 可选表面处理

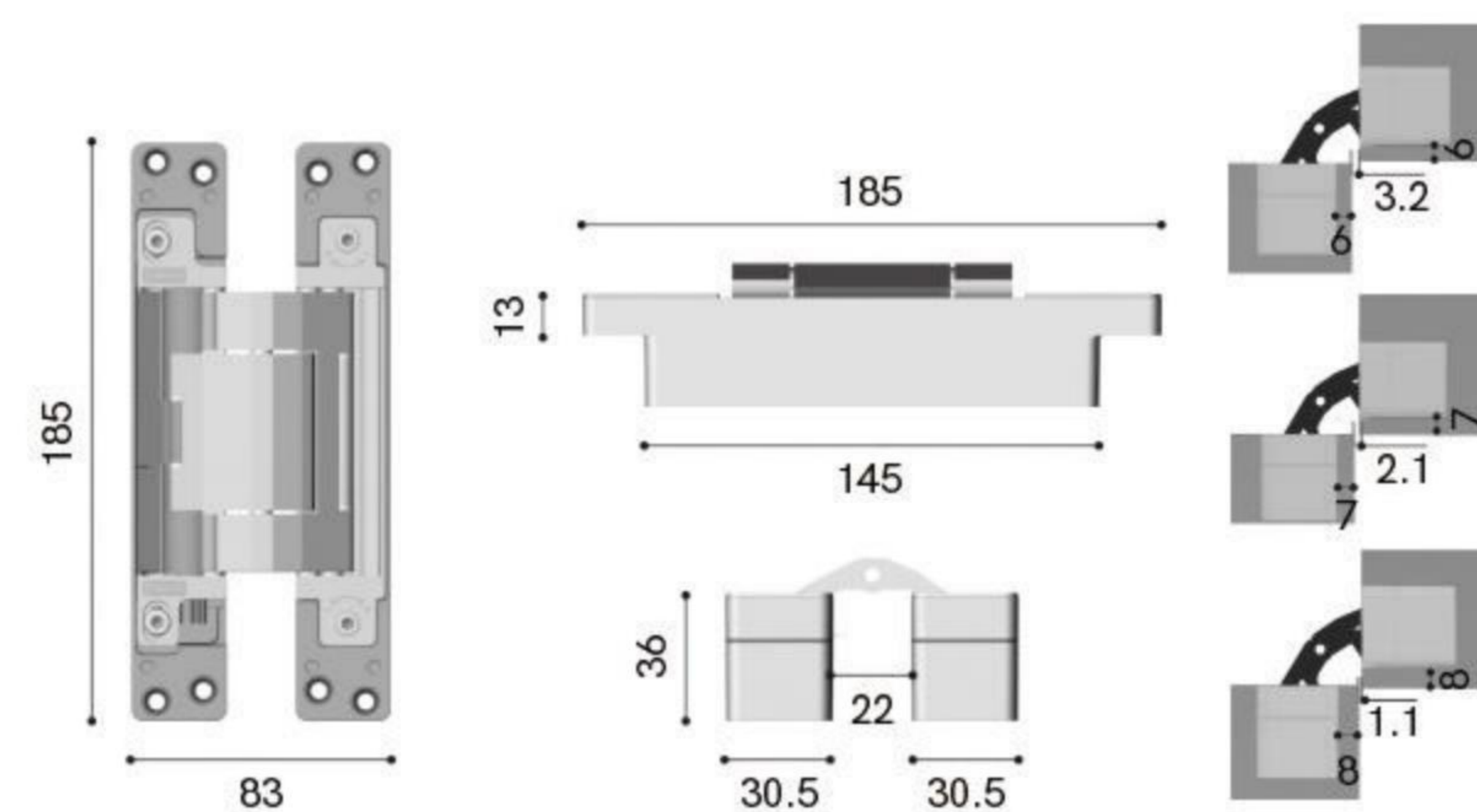

双动力暗藏液压铰链

SL07

功能示意图

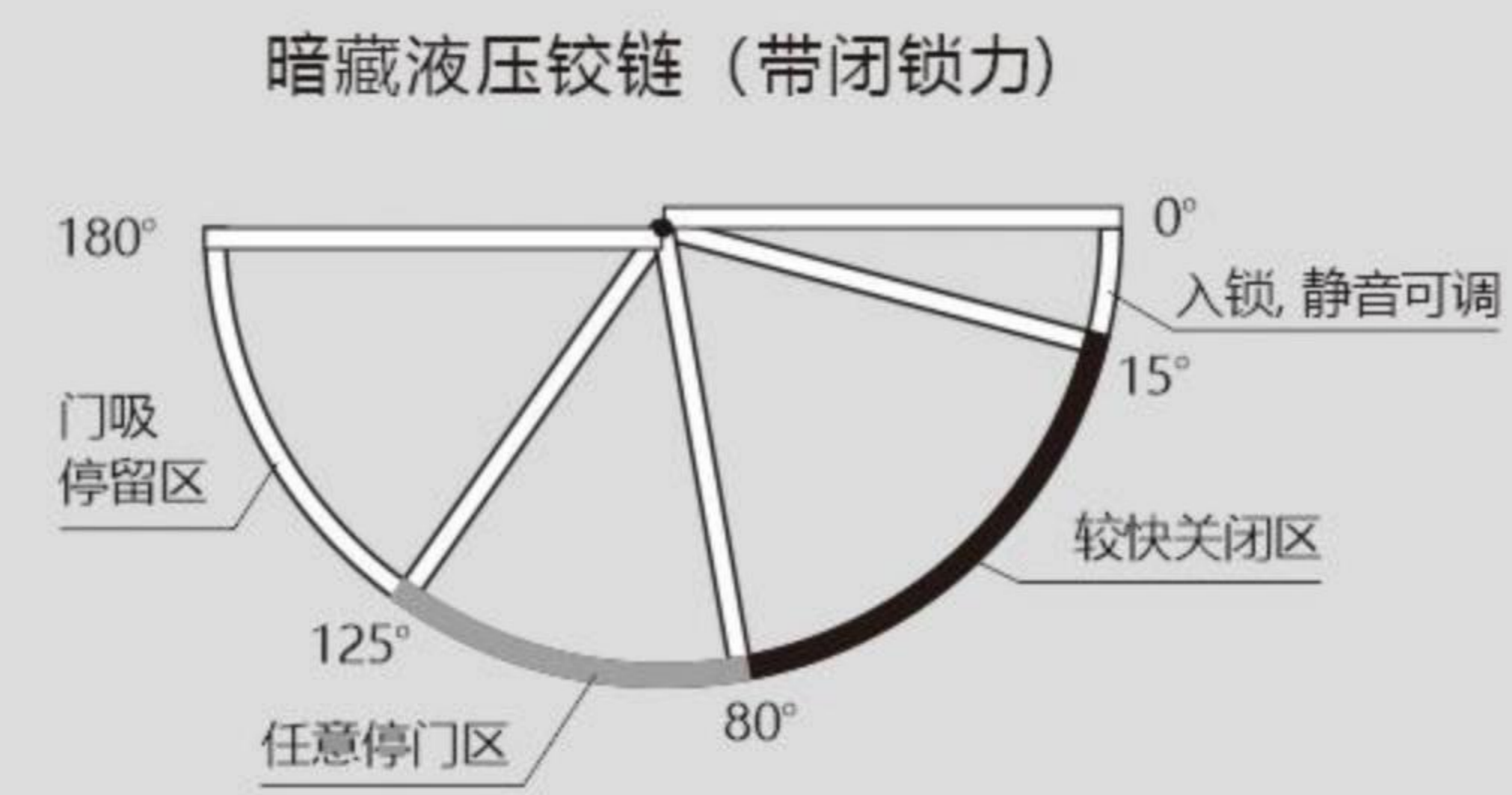

使用注意事项

- 本产品不能用在直接接触雨雪的场所。依据使用闭门器的不同可能会使合页破损或者动作异常从而导致门无法关紧, 请务必先确认。
- 门上的合页出现往下掉时不要大力关门, 会造成合页的破损。
- 门有翘曲或变形时合页可能动作变差造成门无法关紧。
- 使用中要定时确认各部位螺丝有无松动。

性能及参数

- 主体材质: 锌合金。
- 二维可调: 左右 $\pm 2.0\text{mm}$ 上下 $\pm 2.5\text{mm}$
- 最大开启角度: 180°
- 定位停门: $68^\circ - 125^\circ$ 自由停门
- 单只闭门力: $11\text{N}\cdot\text{m}$ 。
- 适用温度范围: $-5^\circ\text{C} - 45^\circ\text{C}$ 。
- 使用寿命: ≥ 20 万次

合页配备	最大承重	门外形尺寸	表面颜色
2只液压	80kg	门厚 $\geq 50\text{mm}$ 门高 $\leq 2800\text{mm}$ 门宽 $\leq 850\text{mm}$	04 哑黑/曜石黑 07 消光铜拉丝 09 哑光黑拉丝 15 白色
1只承重 2只液压	100kg	门厚 $\geq 55\text{mm}$ 门高 $\leq 3000\text{mm}$ 门宽 $\leq 900\text{mm}$	
3只液压	120kg	门厚 $\geq 60\text{mm}$ 门高 $\leq 3000\text{mm}$ 门宽 $\leq 950\text{mm}$	

Finish Options
可选表面处理

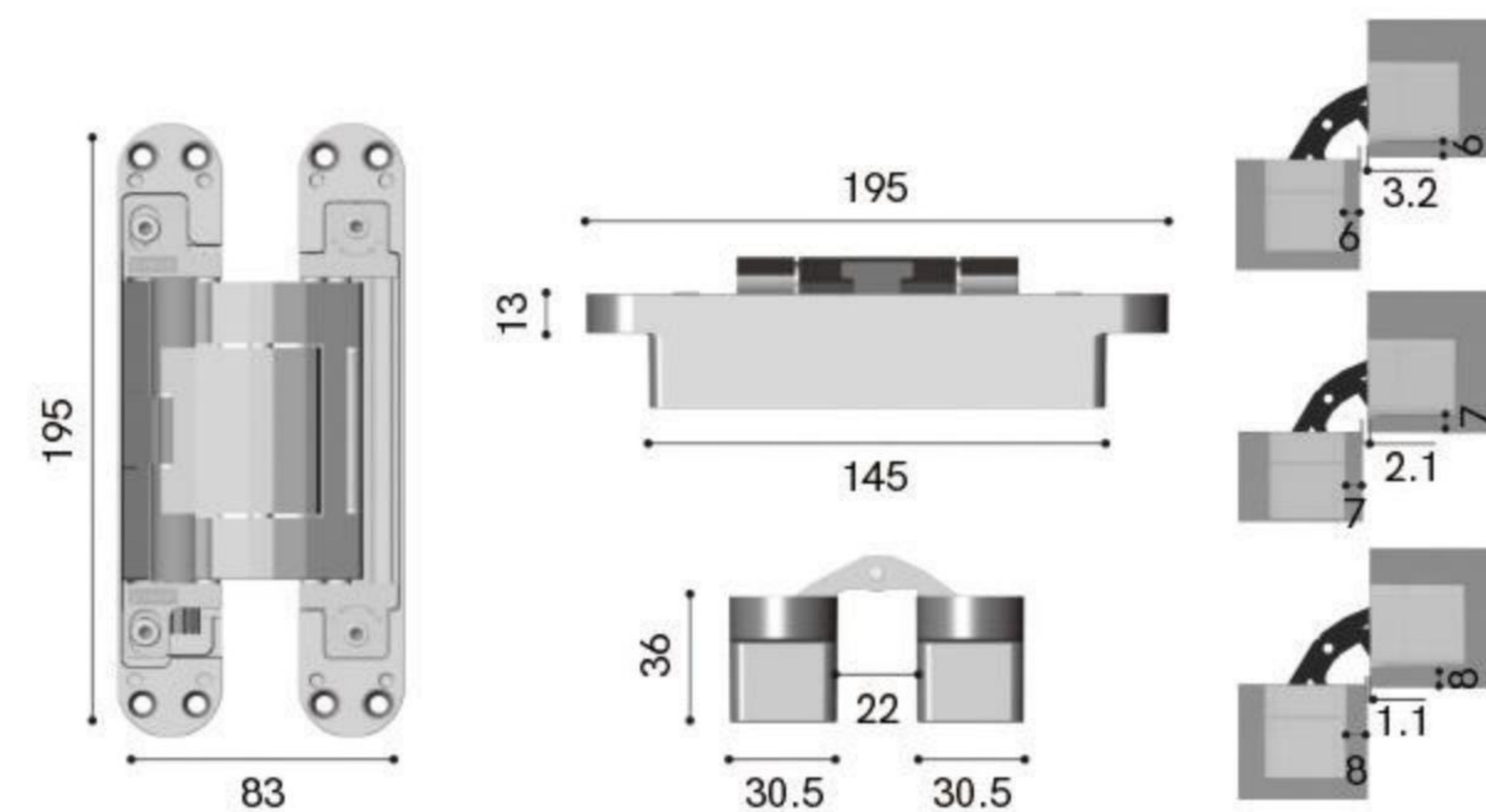
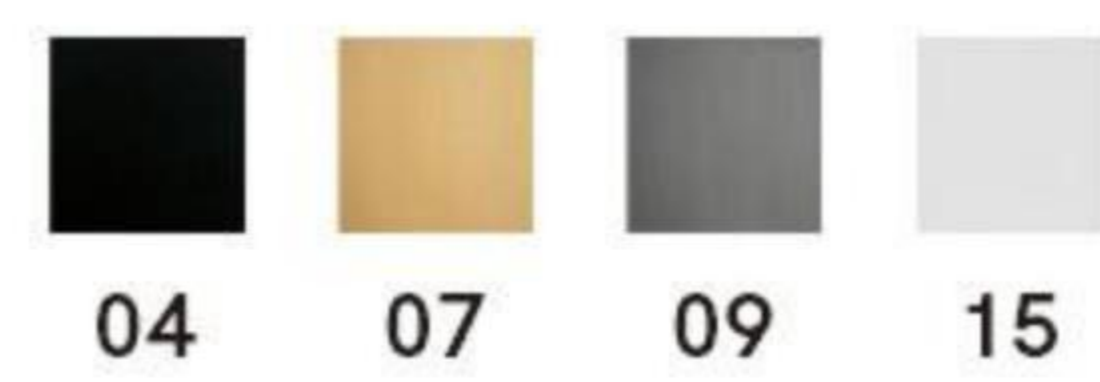

双动力暗藏液压铰链

SL07



Finish Options
可选表面处理

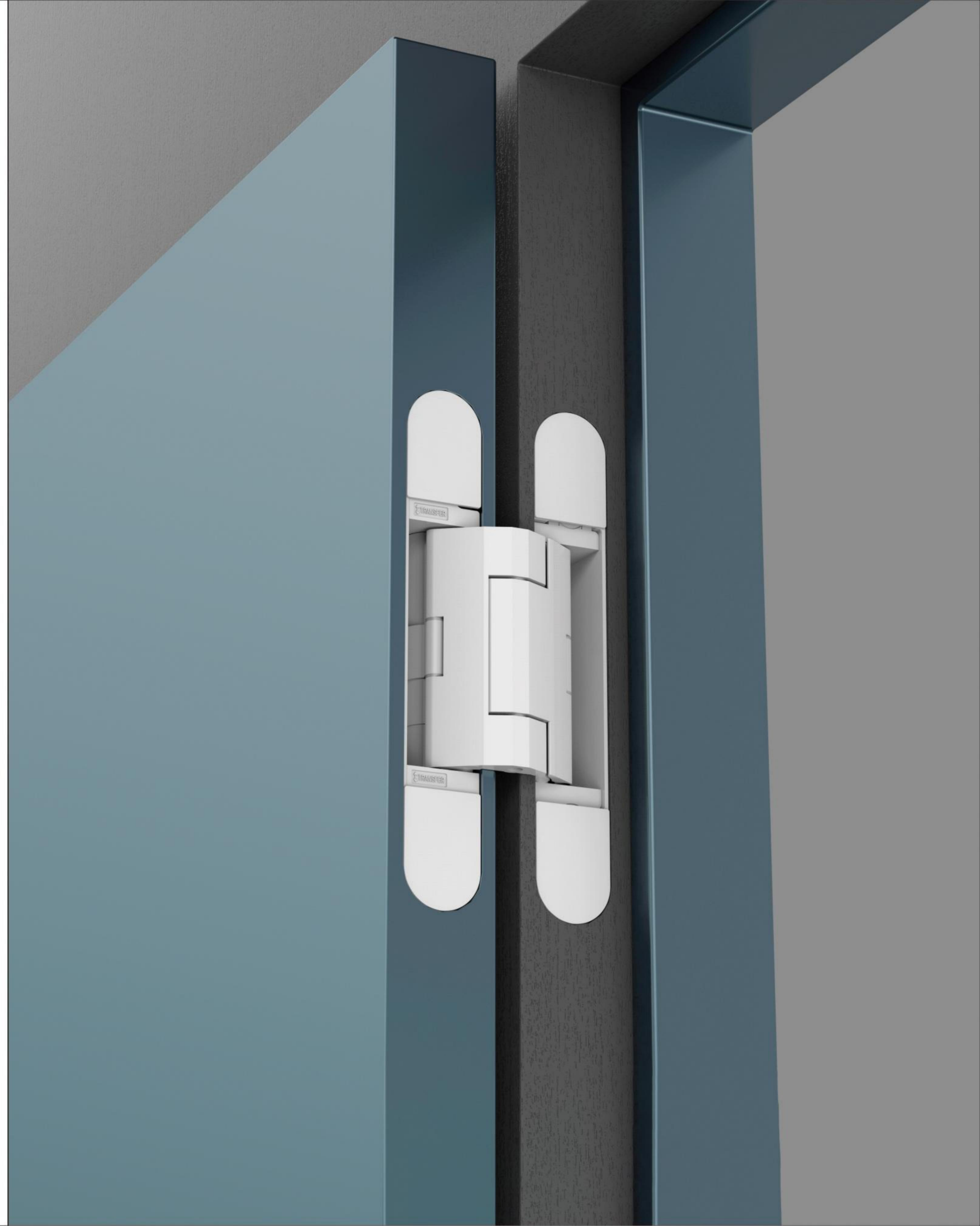
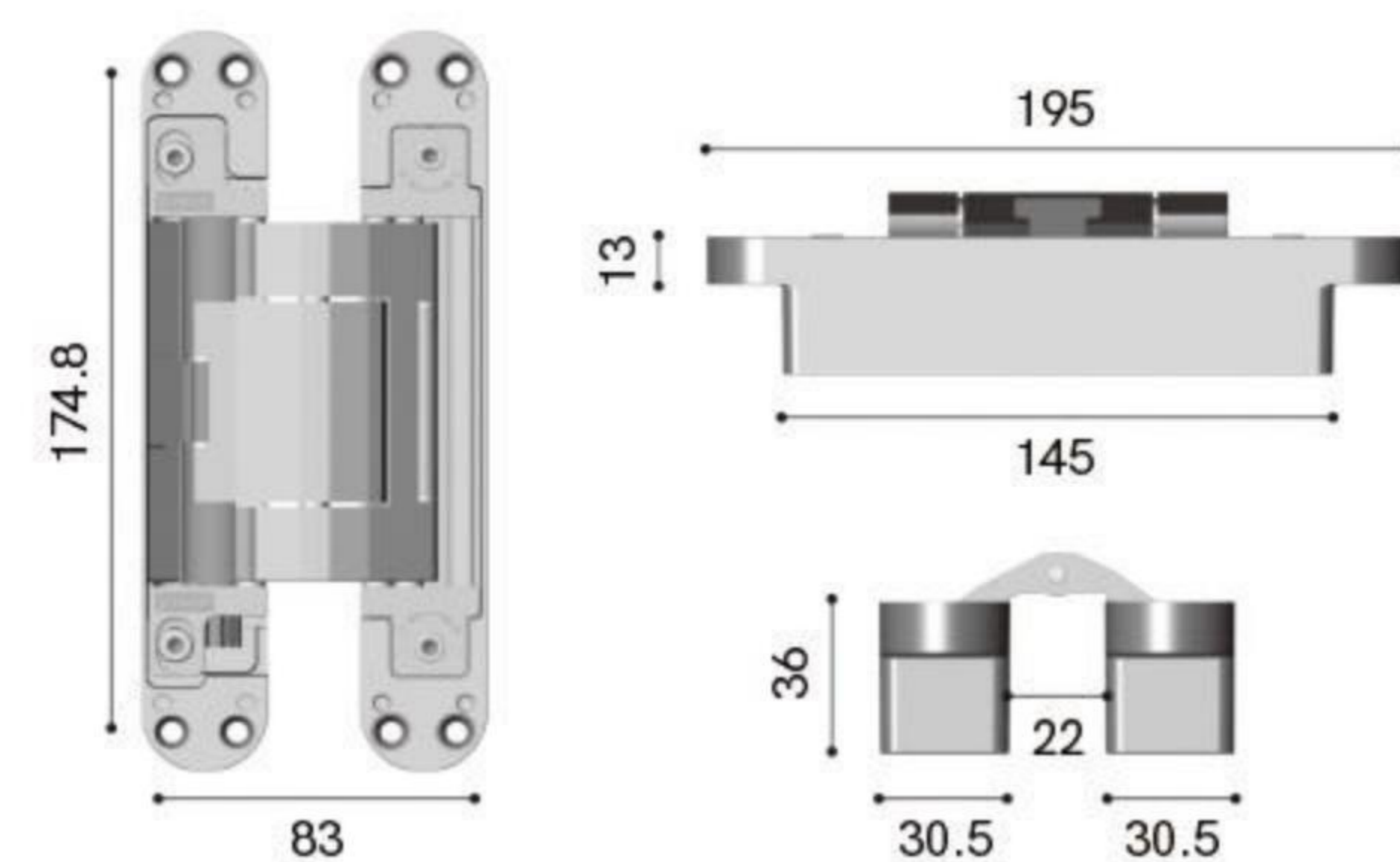

高低脚暗藏液压铰链

SL20

功能示意图

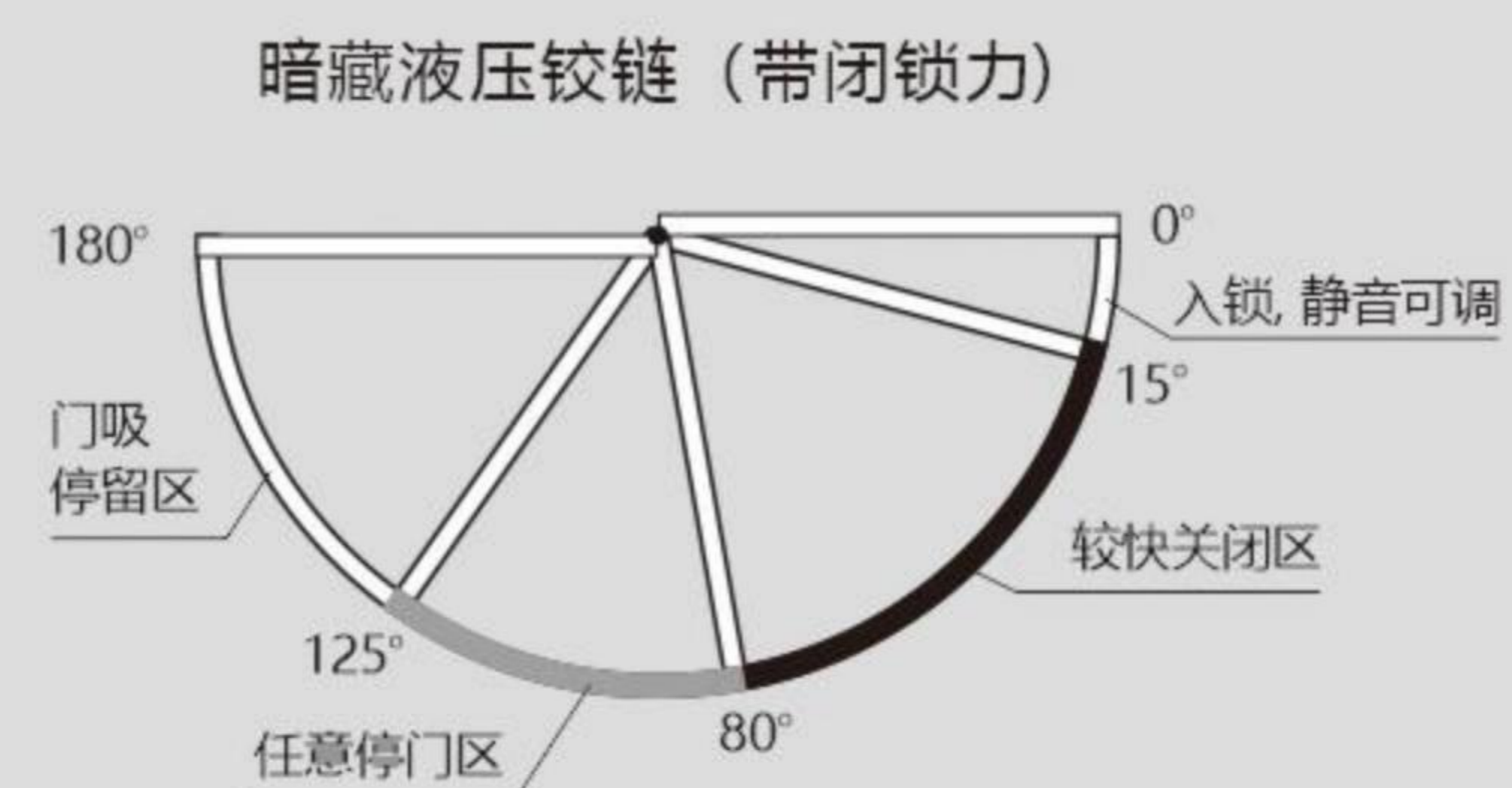

使用注意事项

- 本产品不能用在直接接触雨雪的场所。依据使用闭门器的不同可能会使合页破损或者动作异常从而导致门无法关紧, 请使用前请务必先确认。
- 门上的合页出现往下掉时不要大力关门, 会造成合页的破损。
- 门有翘曲或变形时合页可能动作变差造成门无法关紧。
- 使用中要定时确认各部位螺丝有无松动。

性能及参数

- 主体材质: 锌合金。
- 二维可调: 左右 $\pm 2.0\text{mm}$ 上下 $\pm 2.5\text{mm}$
- 最大开启角度: 180°
- 定位停门: $85^\circ - 125^\circ$ 自由停门
- 单只闭门力: $6\text{N}\cdot\text{m}$ 。
- 适用温度范围: $-5^\circ\text{C} - 45^\circ\text{C}$ 。
- 使用寿命: ≥ 20 万次

合页配备	最大承重	门外形尺寸	表面颜色
2只液压	60kg	门厚 $\geq 42\text{mm}$ 门高 $\leq 2000\text{mm}$ 门宽 $\leq 800\text{mm}$	曜石黑 镍单色
1只承重 2只液压	80kg	门厚 $\geq 45\text{mm}$ 门高 $\leq 2200\text{mm}$ 门宽 $\leq 900\text{mm}$	
3只液压	100kg	门厚 $\geq 50\text{mm}$ 门高 $\leq 2400\text{mm}$ 门宽 $\leq 950\text{mm}$	

Finish Options
可选表面处理

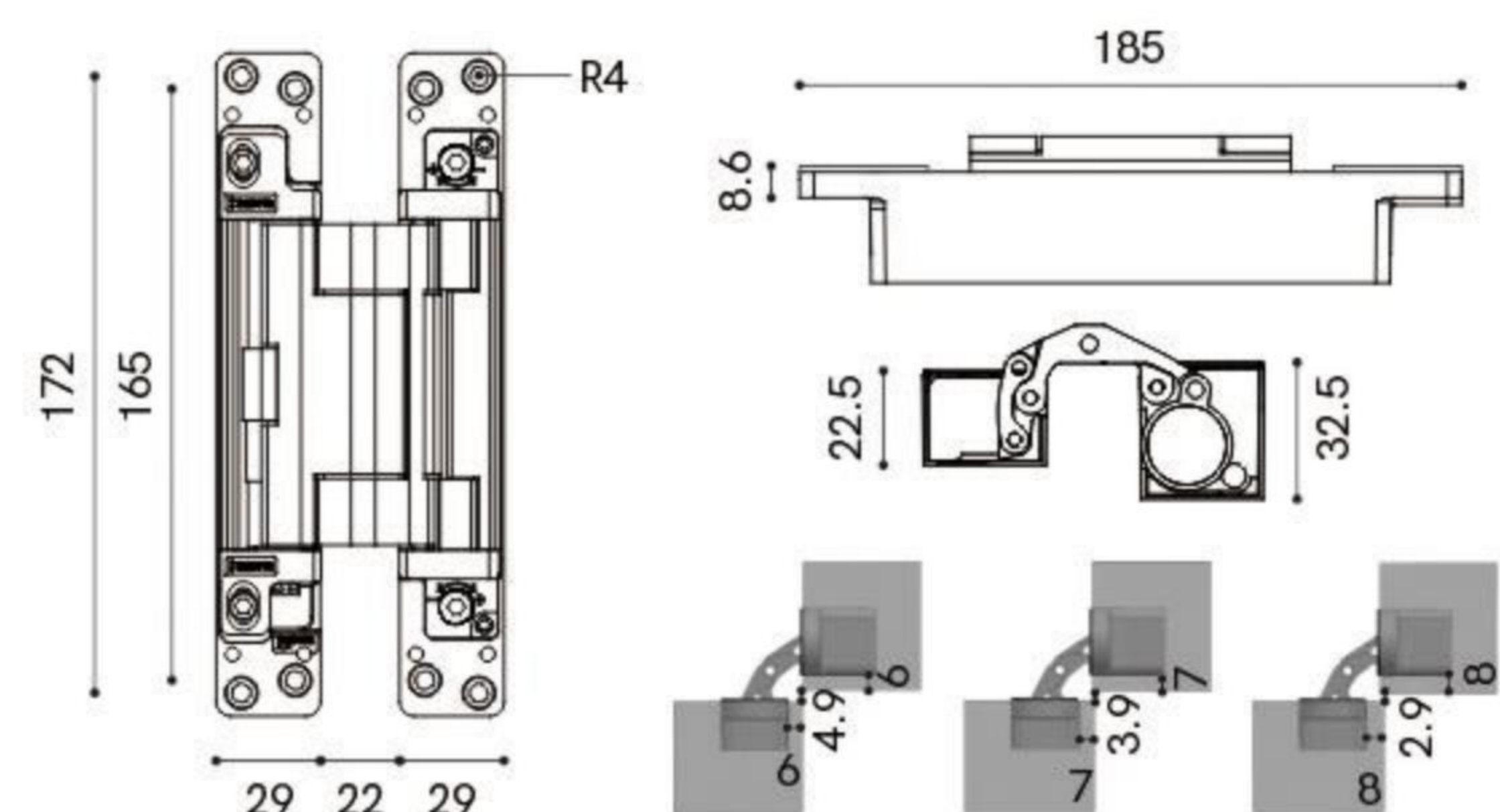
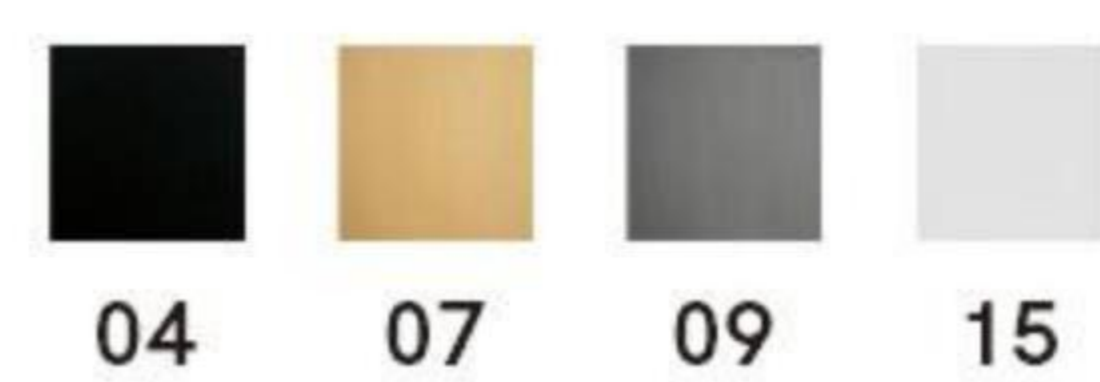

高低脚暗藏液压铰链

SL21

功能示意图

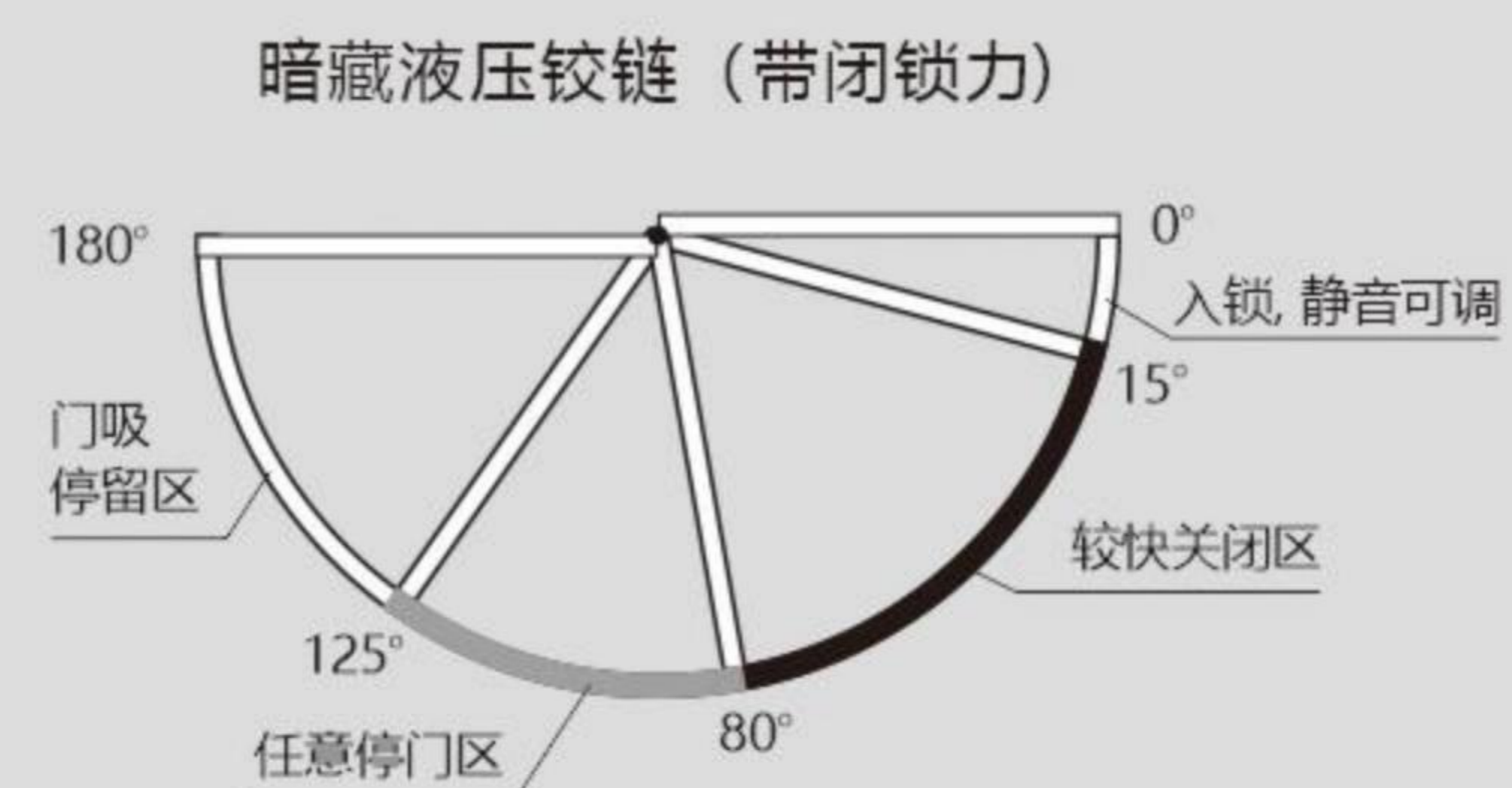

使用注意事项

- 本产品不能用在直接接触雨雪的场所。依据使用闭门器的不同可能会使合页破损或者动作异常从而导致门无法关紧, 请使用前请务必先确认。
- 门上的合页出现往下掉时不要大力关门, 会造成合页的破损。
- 门有翘曲或变形时合页可能动作变差造成门无法关紧。
- 使用中要定时确认各部位螺丝有无松动。

性能及参数

- 主体材质: 锌合金。
- 二维可调: 左右 $\pm 2.0\text{mm}$ 上下 $\pm 2.5\text{mm}$
- 最大开启角度: 180°
- 定位停门: $85^\circ - 125^\circ$ 自由停门
- 单只闭门力: $6\text{N}\cdot\text{m}$ 。
- 适用温度范围: $-5^\circ\text{C} - 45^\circ\text{C}$ 。
- 使用寿命: ≥ 20 万次

合页配备	最大承重	门外形尺寸	表面颜色
2只液压	60kg	门厚 $\geq 42\text{mm}$ 门高 $\leq 2000\text{mm}$ 门宽 $\leq 800\text{mm}$	曜石黑 镍单色
1只承重 2只液压	80kg	门厚 $\geq 45\text{mm}$ 门高 $\leq 2200\text{mm}$ 门宽 $\leq 900\text{mm}$	
3只液压	100kg	门厚 $\geq 50\text{mm}$ 门高 $\leq 2400\text{mm}$ 门宽 $\leq 950\text{mm}$	

Finish Options 可选表面处理

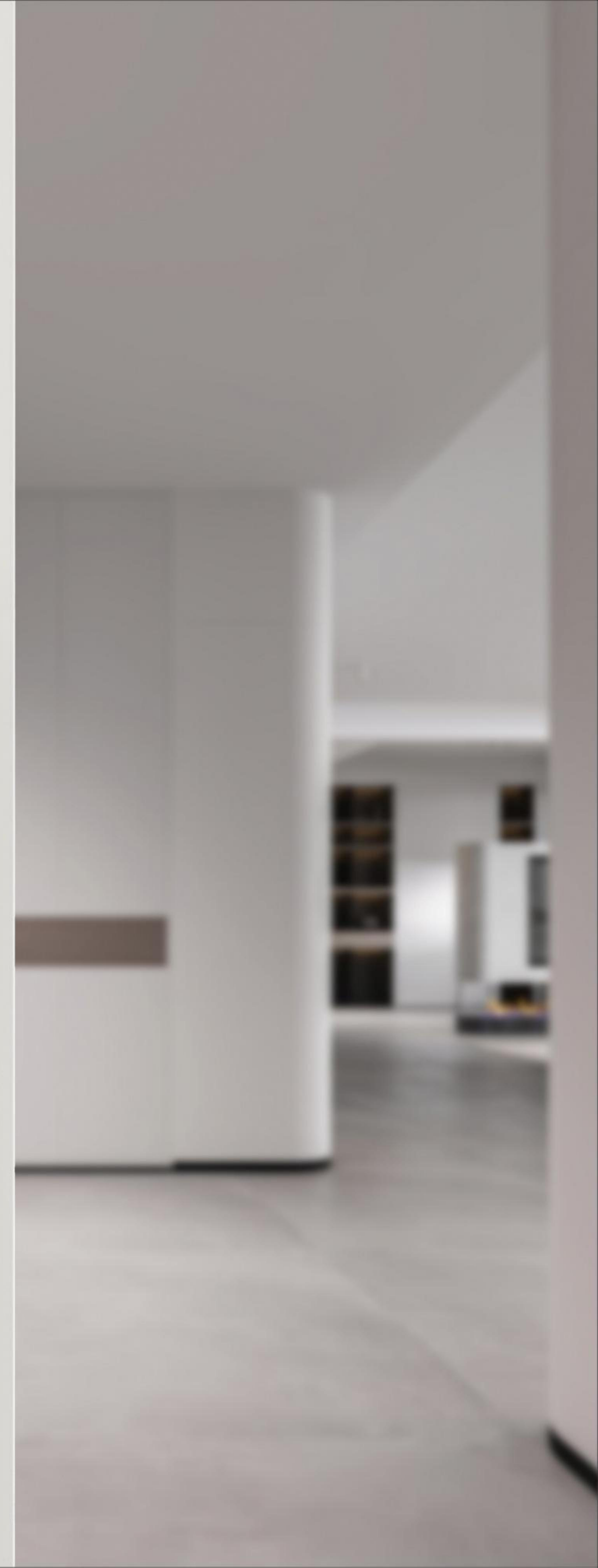
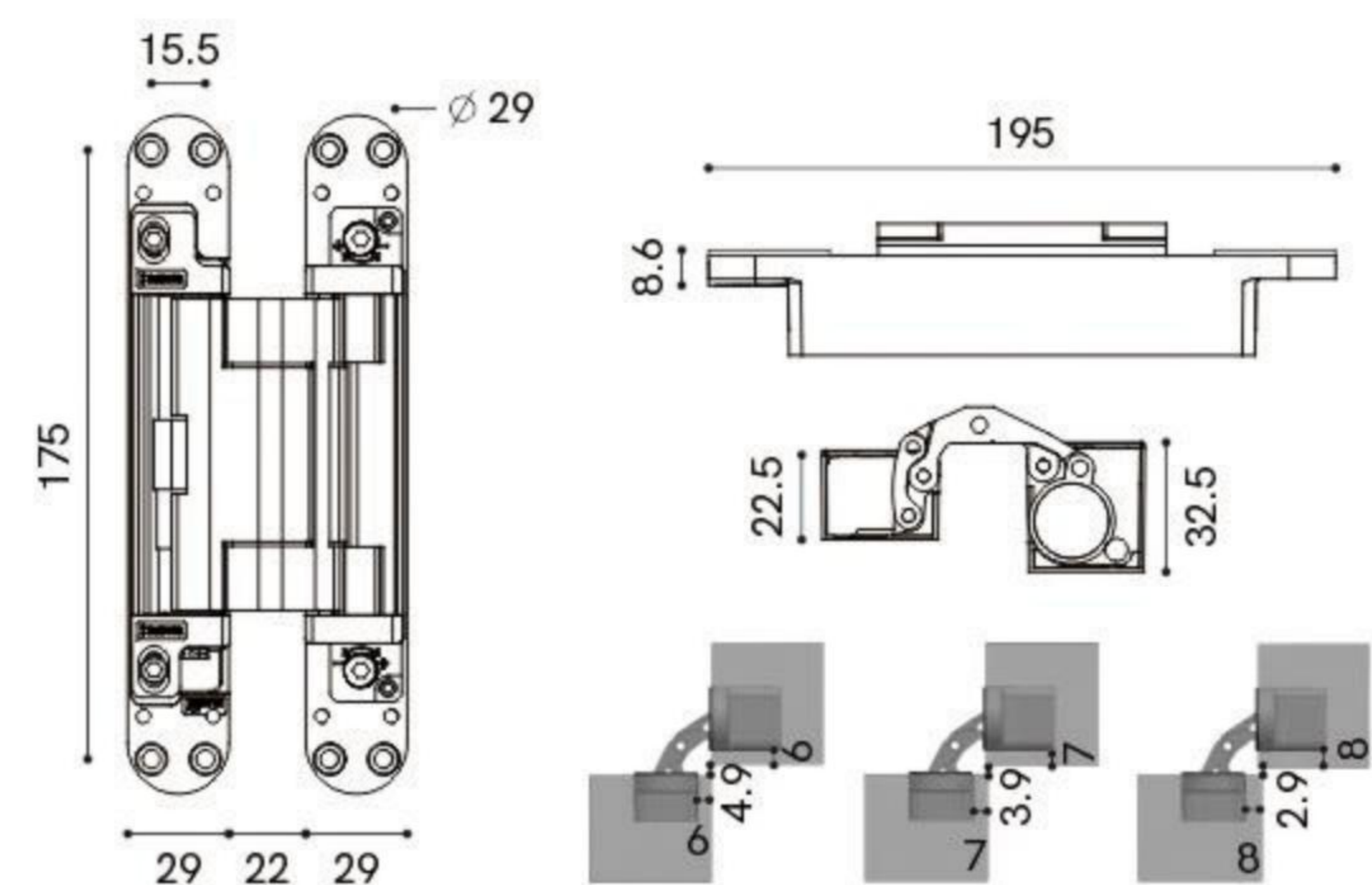
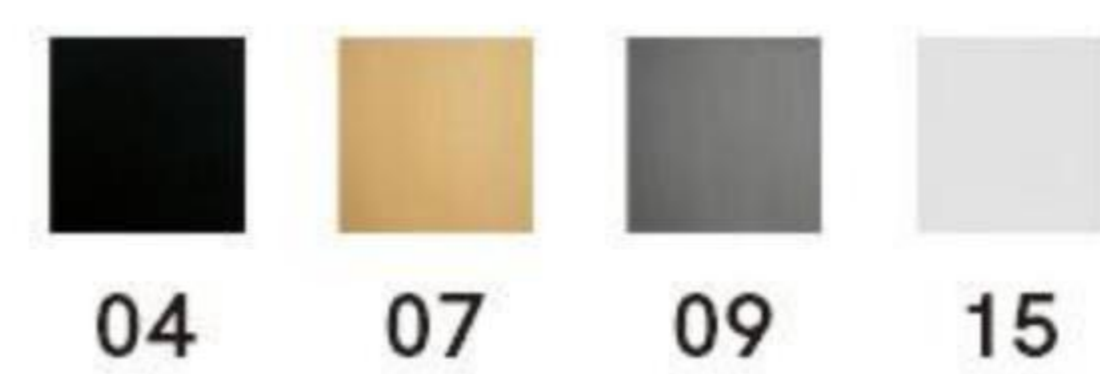

双动力暗藏液压铰链

SL25

功能示意图

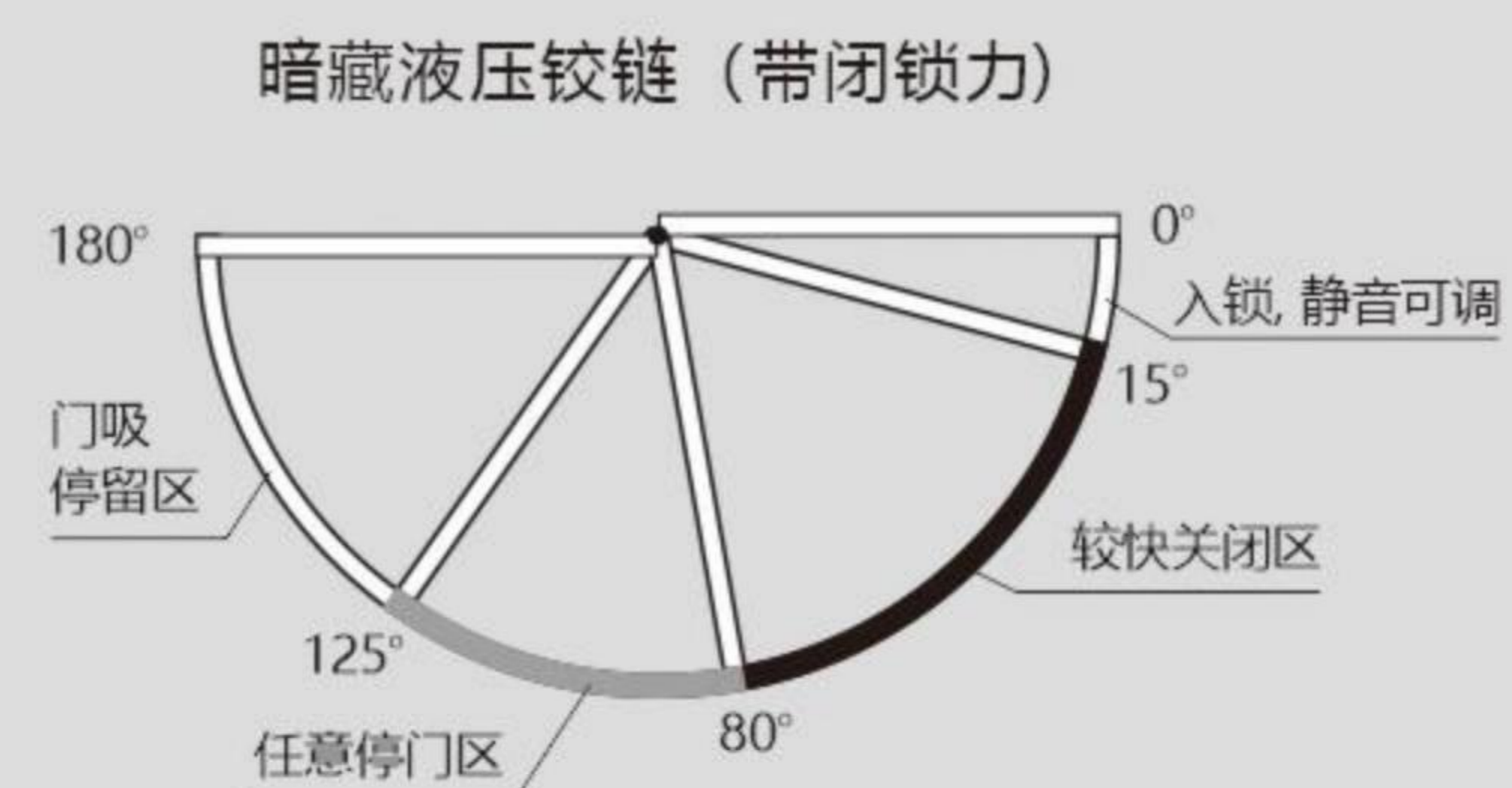

使用注意事项

- 本产品不能用在直接接触雨雪的场所。依据使用闭门器的不同可能会使合页破损或者动作异常从而导致门无法关紧，请使用前请务必先确认。
- 门上的合页出现往下掉时不要大力关门，会造成合页的破损。
- 门有翘曲或变形时合页可能动作变差造成门无法关紧。
- 使用中要定时确认各部位螺丝有无松动。

性能及参数

- 主体材质: 锌合金。
- 二维可调: 左右 ±2.0mm 上下 ±2.5mm
- 最大开启角度: 180°
- 定位停门: 68°—125°自由停门
- 单只闭门力: 11N.m。
- 适用温度范围: -5°C - 45°C。
- 使用寿命: ≥20万次

合页配备	最大承重	门外形尺寸	表面颜色
2只液压	80kg	门厚 ≥50mm 门高 ≤2800mm 门宽 ≤850mm	04 哑黑/曜石黑 07 消光铜拉丝 09 哑光黑拉丝 15 白色
1只承重 2只液压	100kg	门厚 ≥55mm 门高 ≤3000mm 门宽 ≤900mm	
3只液压	120kg	门厚 ≥60mm 门高 ≤3000mm 门宽 ≤950mm	

Finish Options 可选表面处理

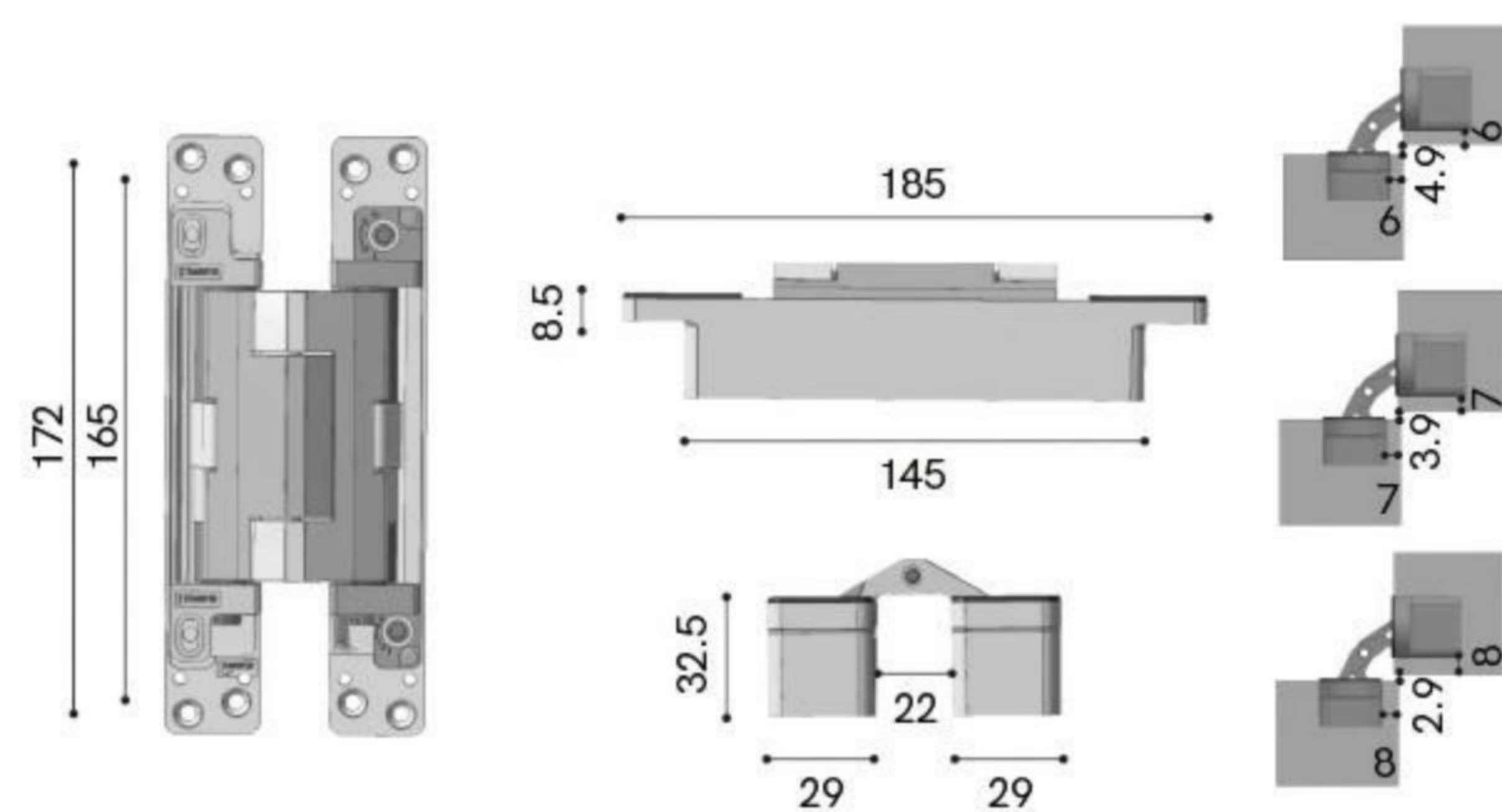
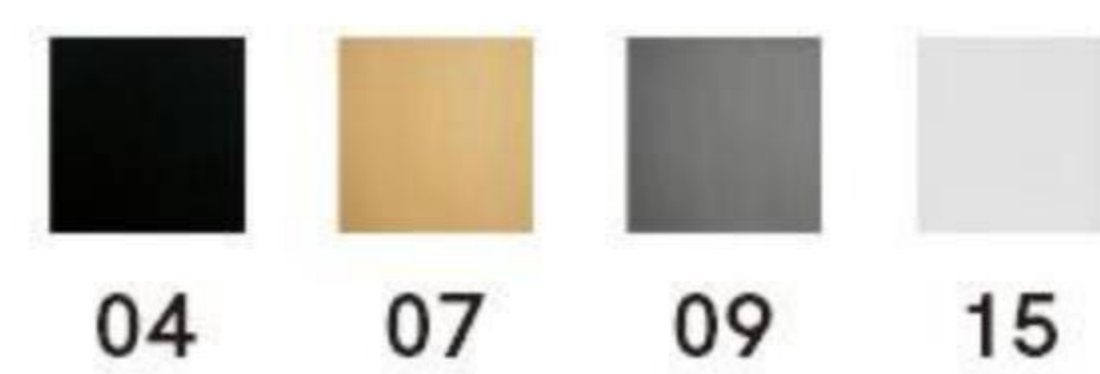

双动力暗藏液压铰链

SL26

功能示意图

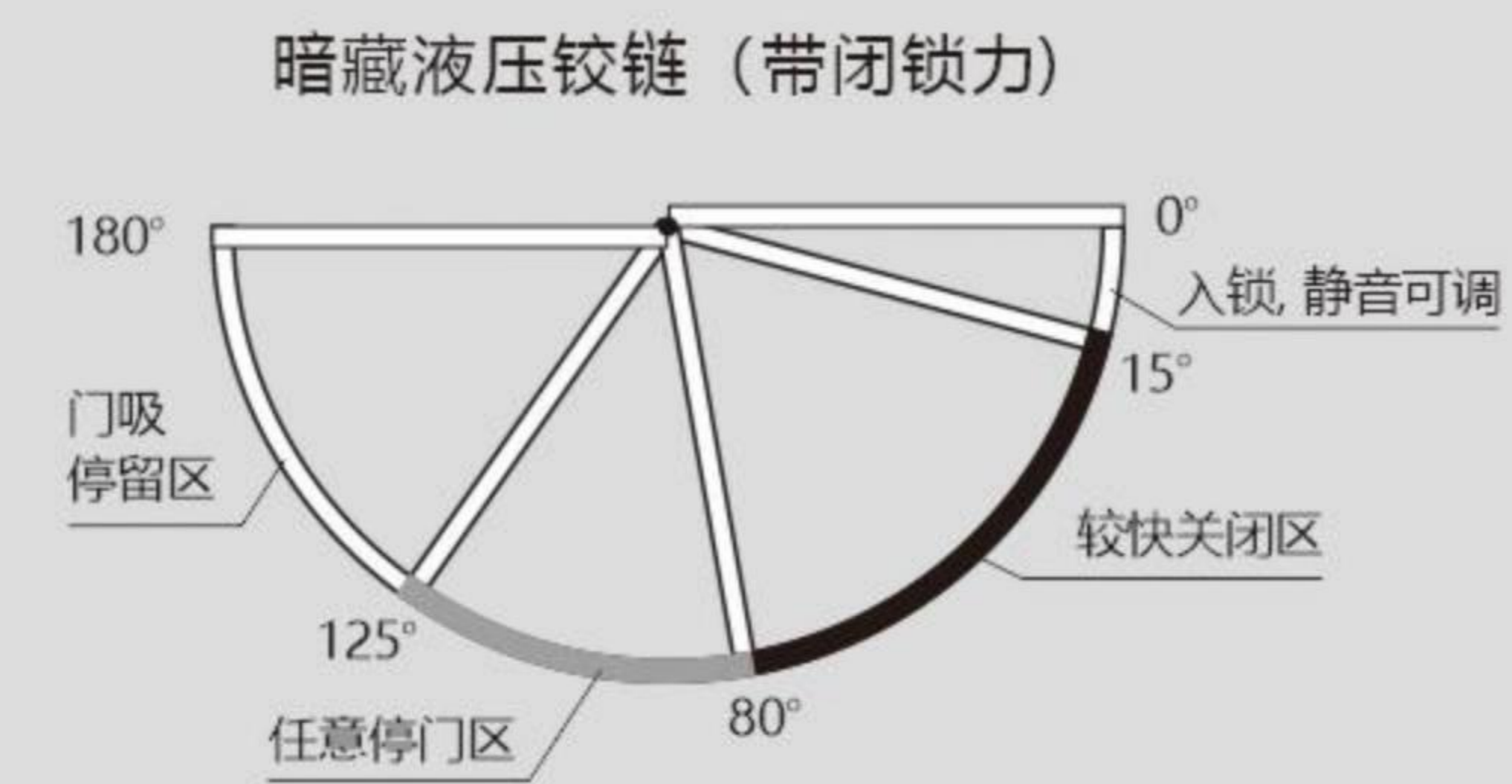

使用注意事项

- 本产品不能用在直接接触雨雪的场所。依据使用闭门器的不同可能会使合页破损或者动作异常从而导致门无法关紧, 请使用前请务必先确认。
- 门上的合页出现往下掉时不要大力关门, 会造成合页的破损。
- 门有翘曲或变形时合页可能动作变差造成门无法关紧。
- 使用中要定时确认各部位螺丝有无松动。

性能及参数

- 主体材质: 锌合金。
- 二维可调: 左右 $\pm 2.0\text{mm}$ 上下 $\pm 2.5\text{mm}$
- 最大开启角度: 180°
- 定位停门: $68^\circ - 125^\circ$ 自由停门
- 单只闭门力: $11\text{N}\cdot\text{m}$ 。
- 适用温度范围: $-5^\circ\text{C} - 45^\circ\text{C}$ 。
- 使用寿命: ≥ 20 万次

合页配备	最大承重	门外形尺寸	表面颜色
2只液压	80kg	门厚 $\geq 50\text{mm}$ 门高 $\leq 2800\text{mm}$ 门宽 $\leq 850\text{mm}$	04 哑黑/曜石黑 07 消光铜拉丝 09 哑光黑拉丝 15 白色
1只承重 2只液压	100kg	门厚 $\geq 55\text{mm}$ 门高 $\leq 3000\text{mm}$ 门宽 $\leq 900\text{mm}$	
3只液压	120kg	门厚 $\geq 60\text{mm}$ 门高 $\leq 3000\text{mm}$ 门宽 $\leq 950\text{mm}$	

Finish Options
可选表面处理

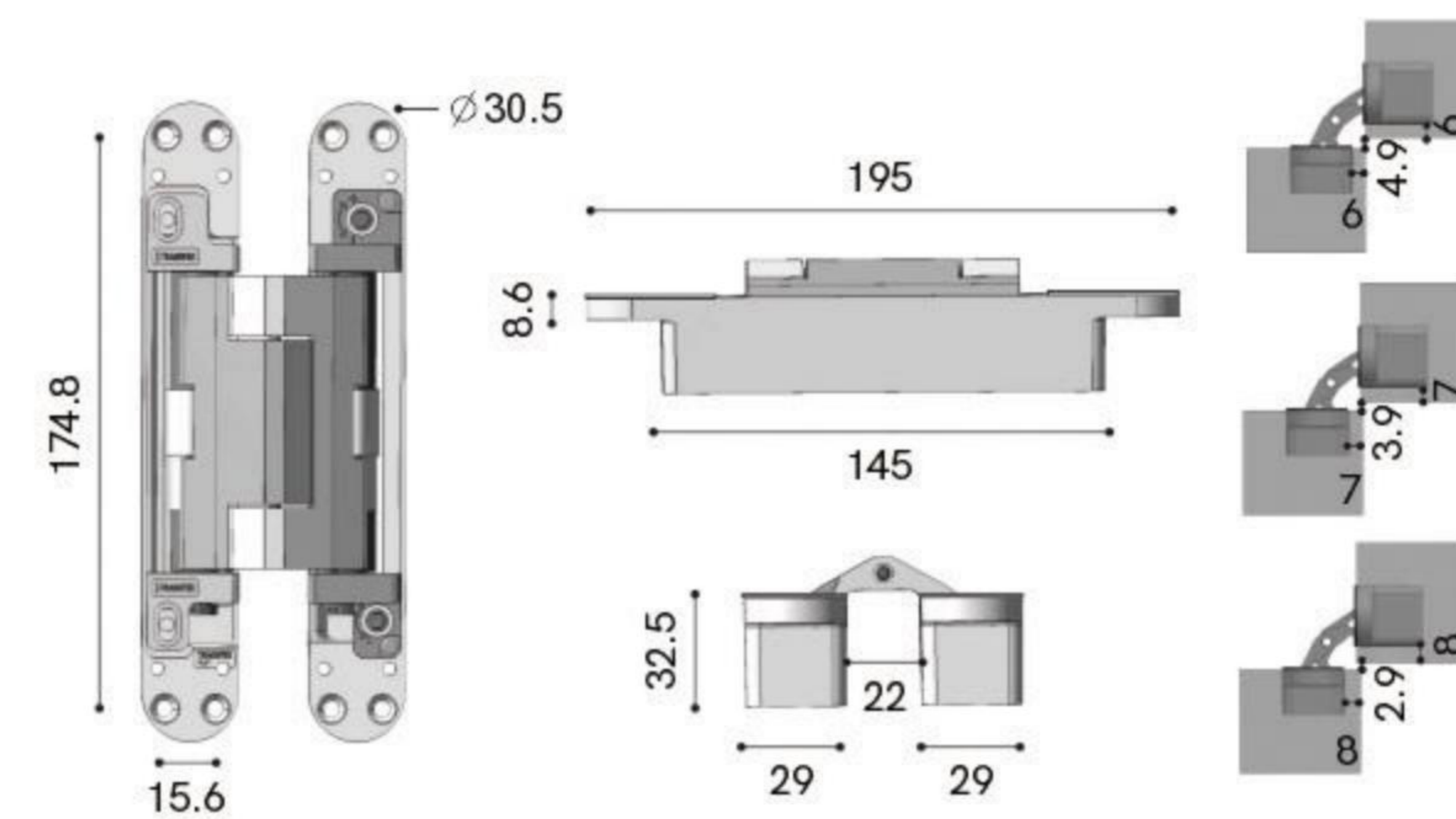
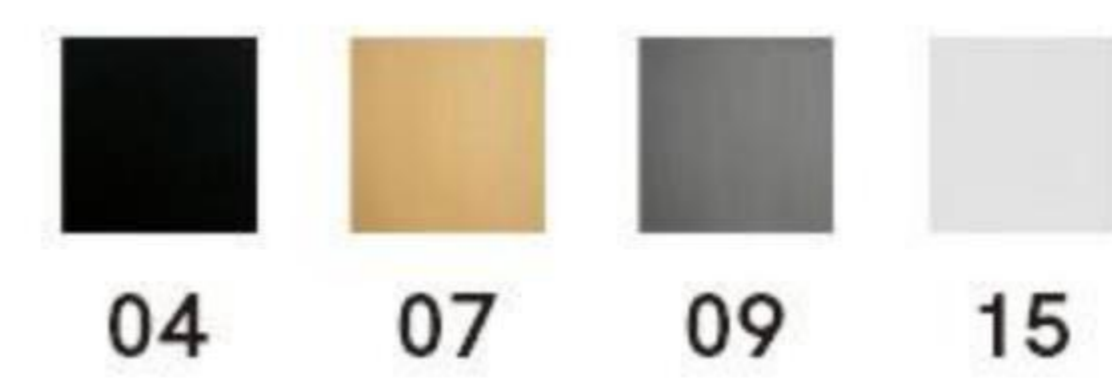

三维可调隐藏铰链

3W-60



Finish Options
可选表面处理

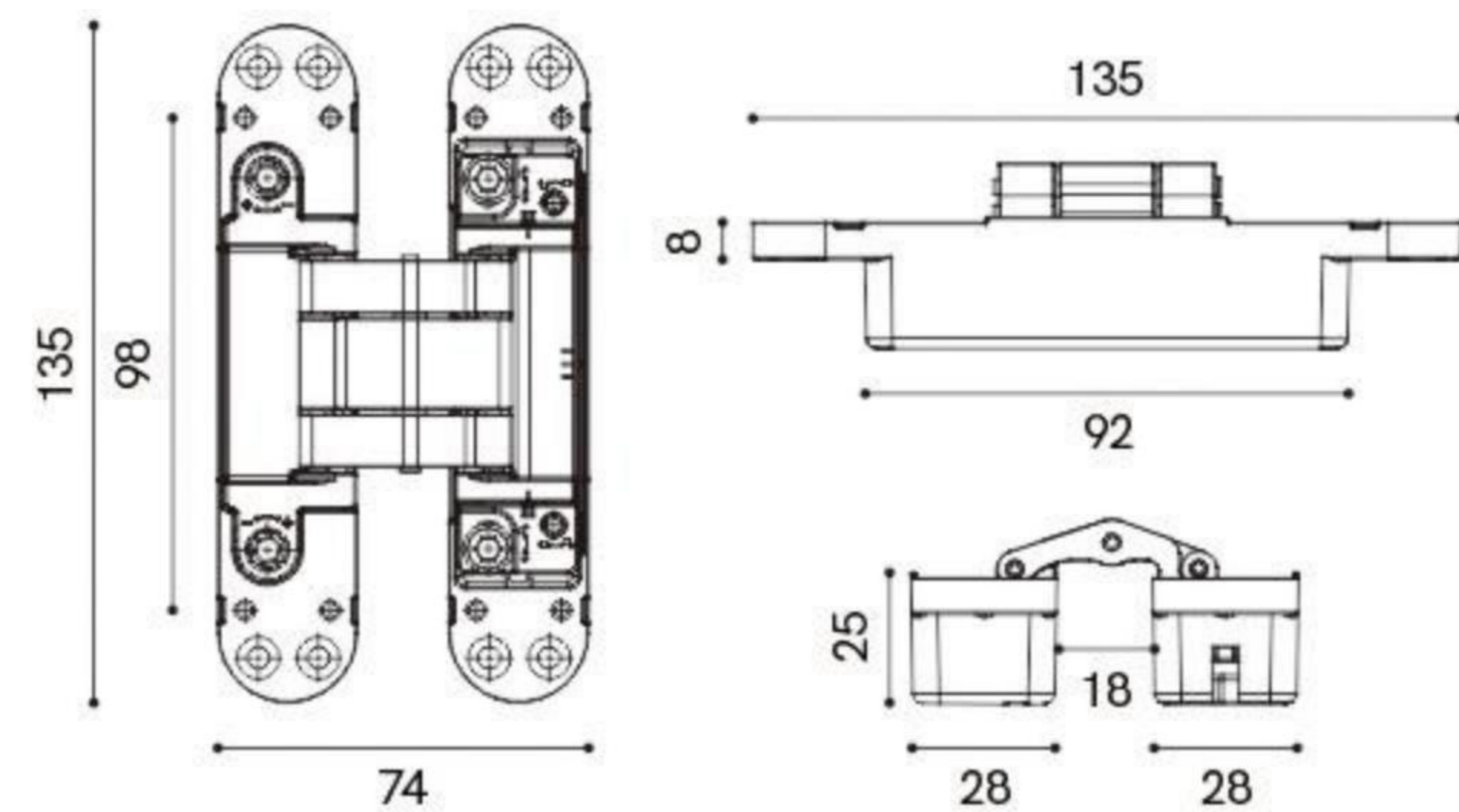
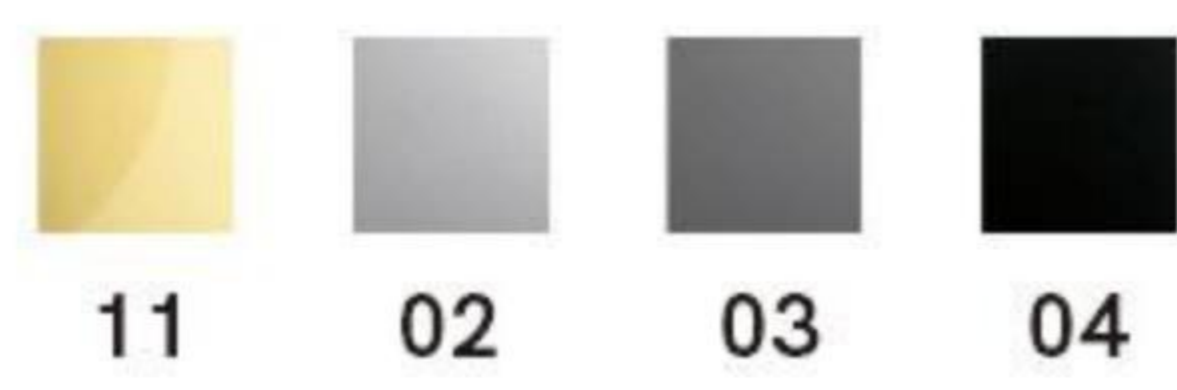

三维可调隐藏铰链

3W-6866



Finish Options
可选表面处理

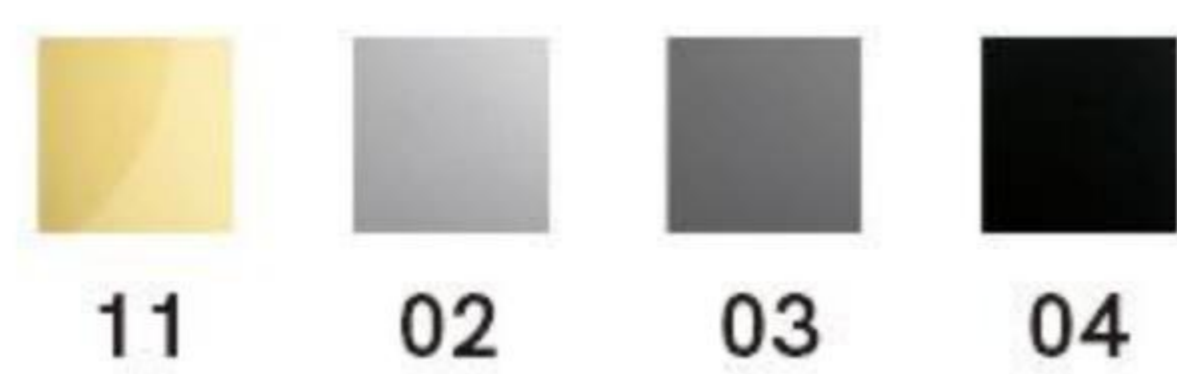

11 02 03 04

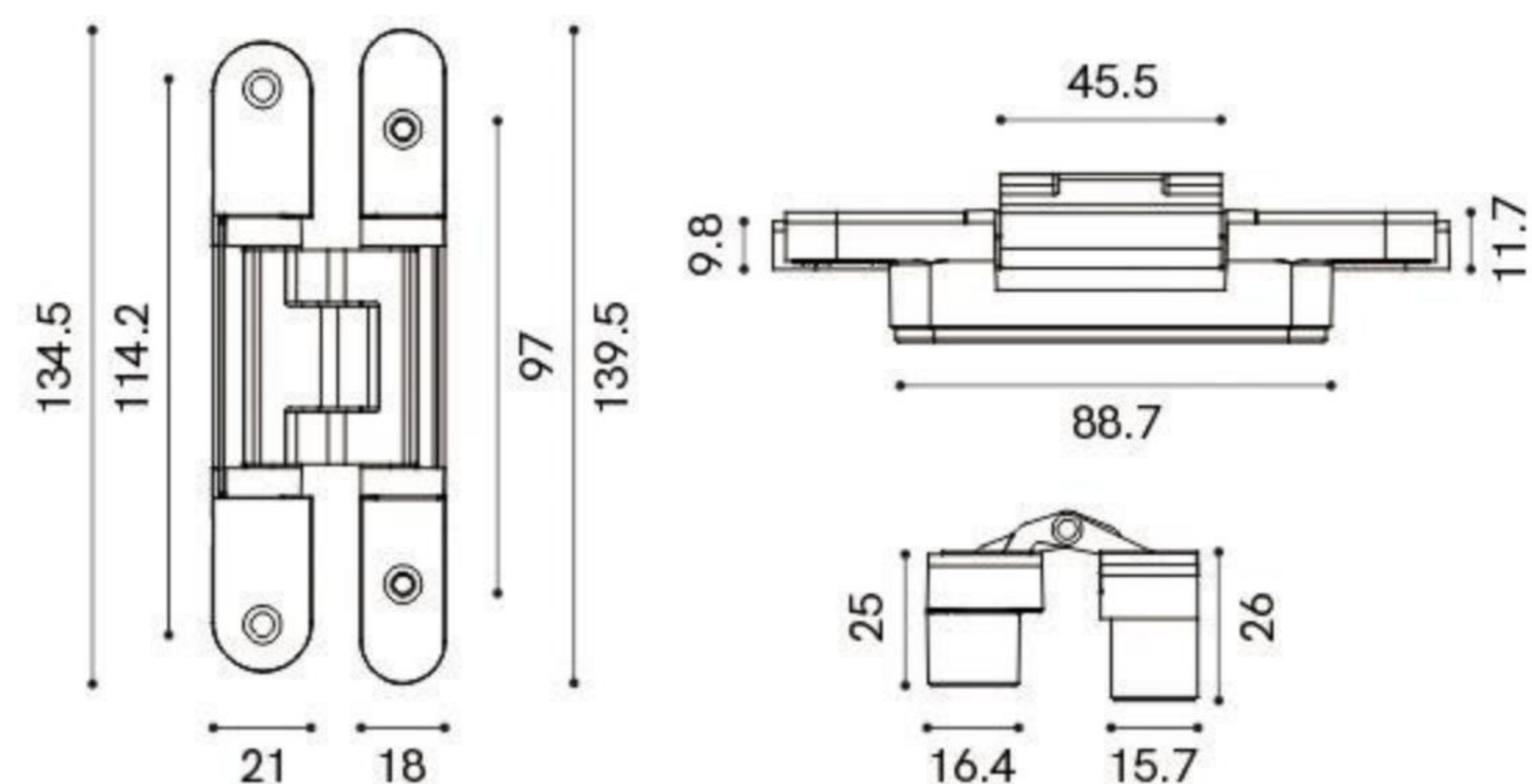

三维可调隐藏铰链

3W-6899



Finish Options
可选表面处理

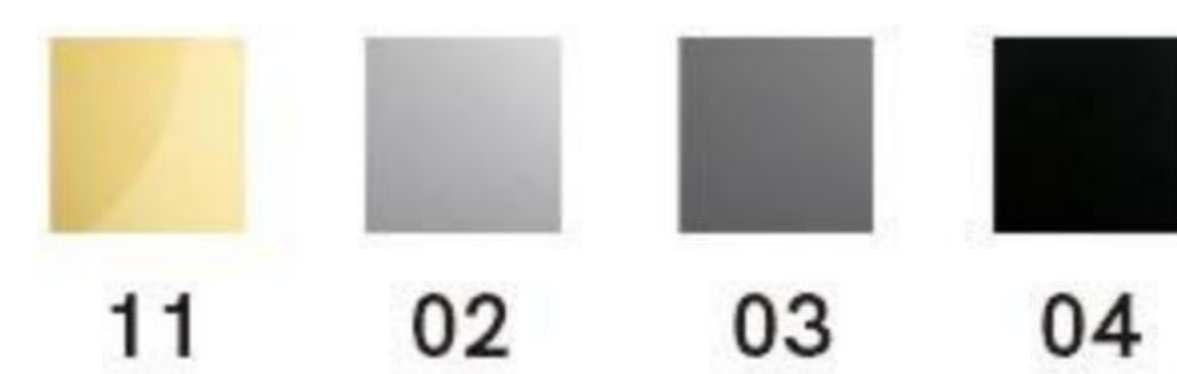

11 02 03 04

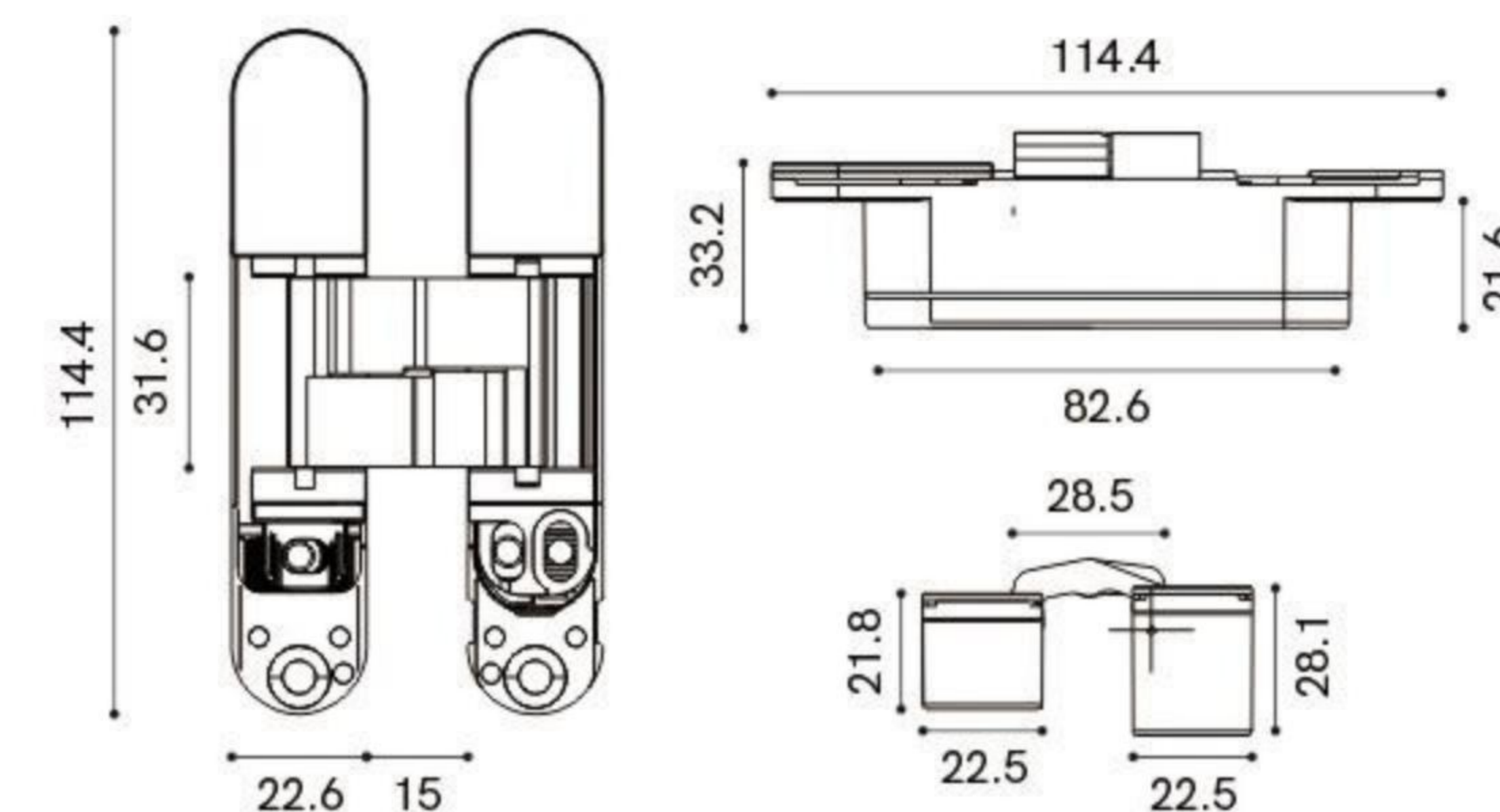

三维可调隐藏铰链

3W-6877



Finish Options
可选表面处理

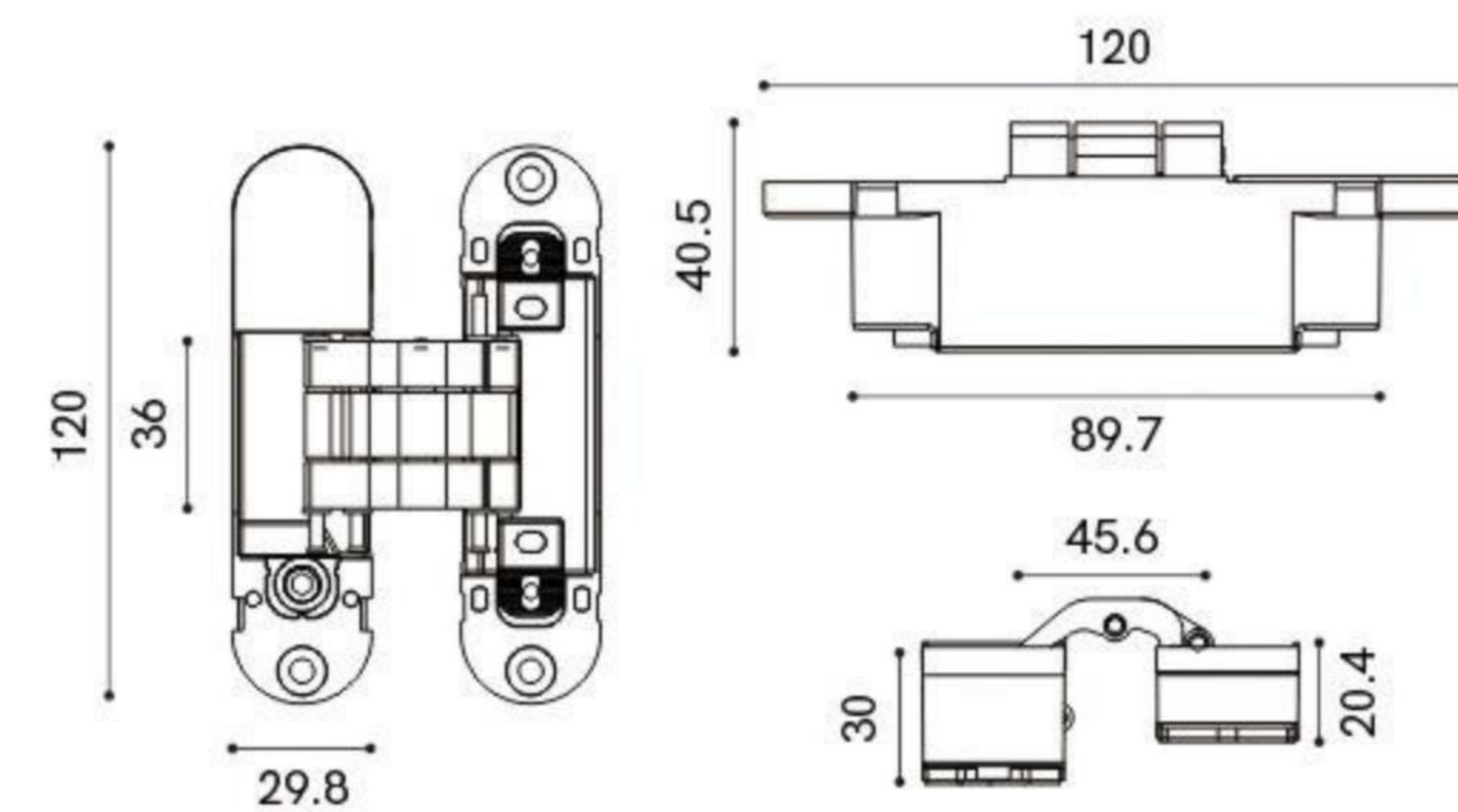
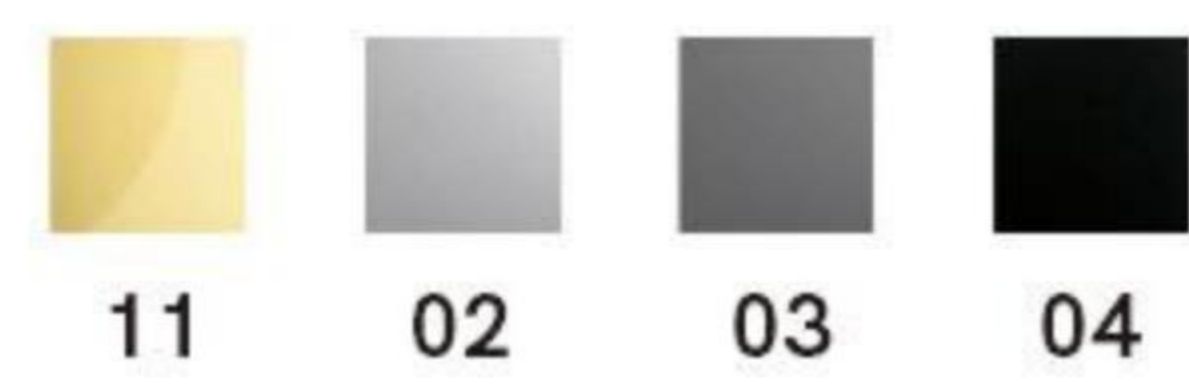

三维可调隐藏铰链

3W-6888



Finish Options
可选表面处理

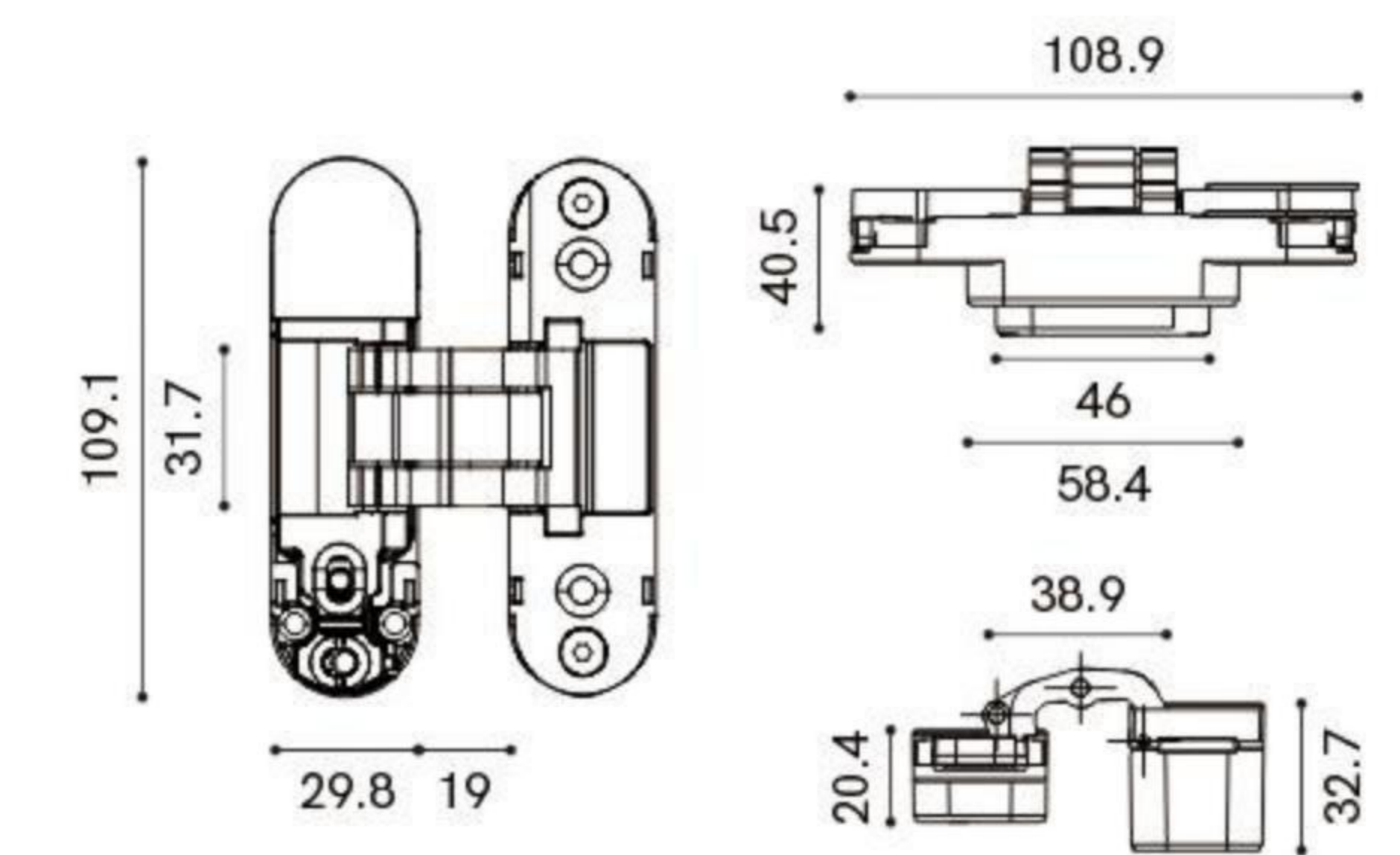
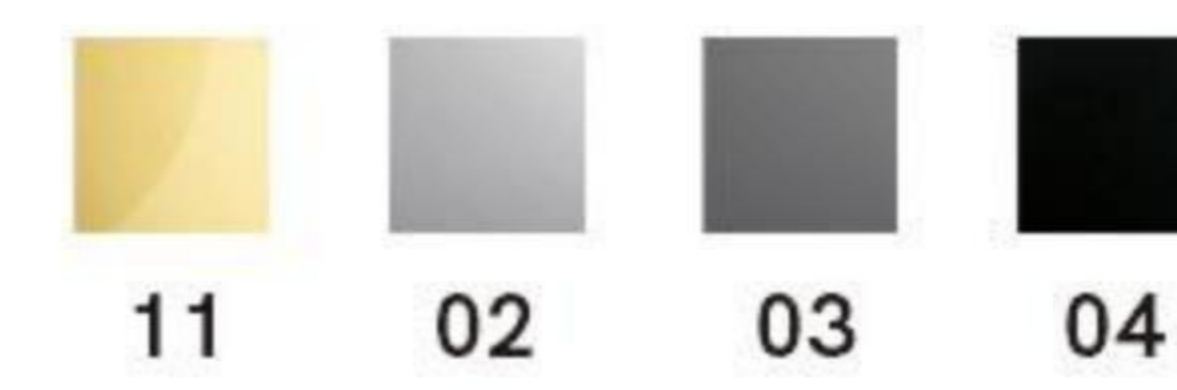

三维可调隐藏铰链

3W-6822



Finish Options
可选表面处理

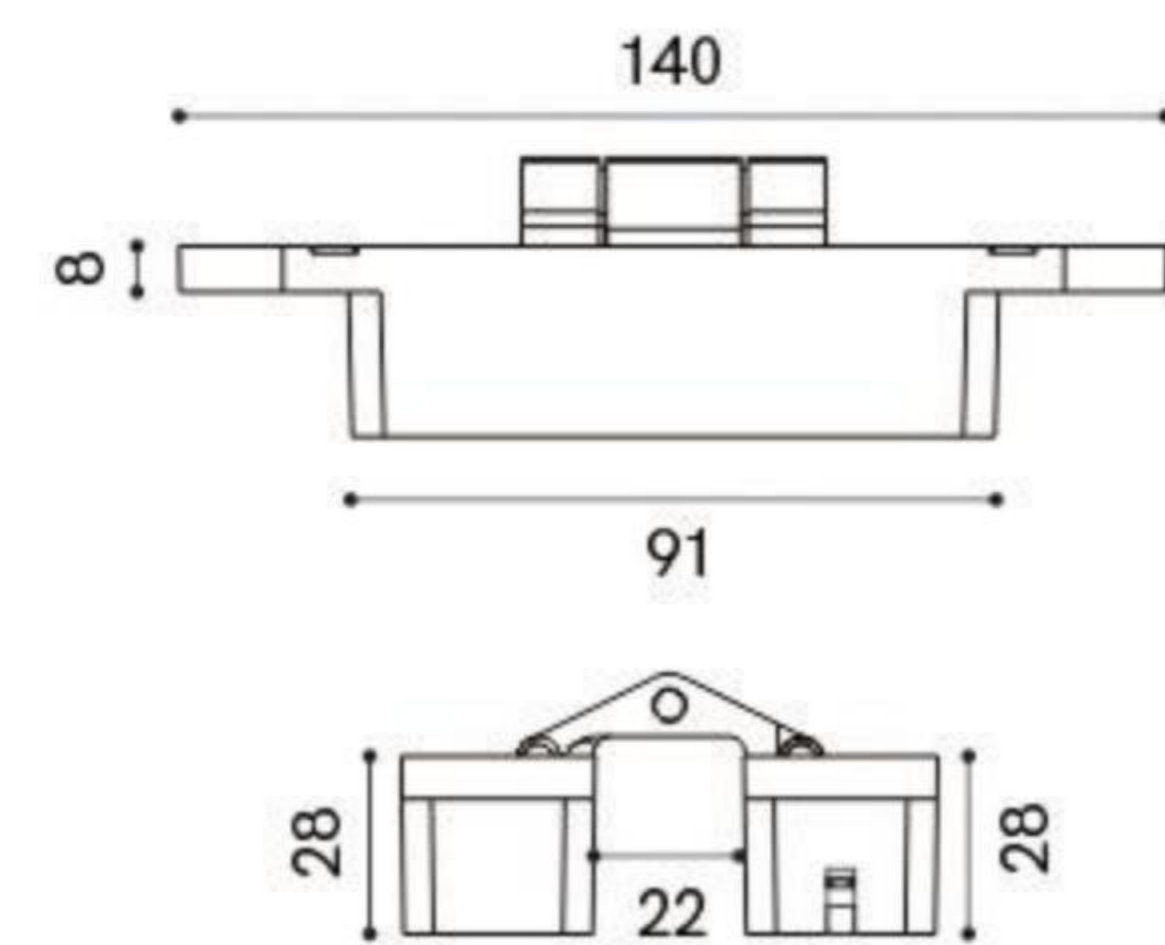
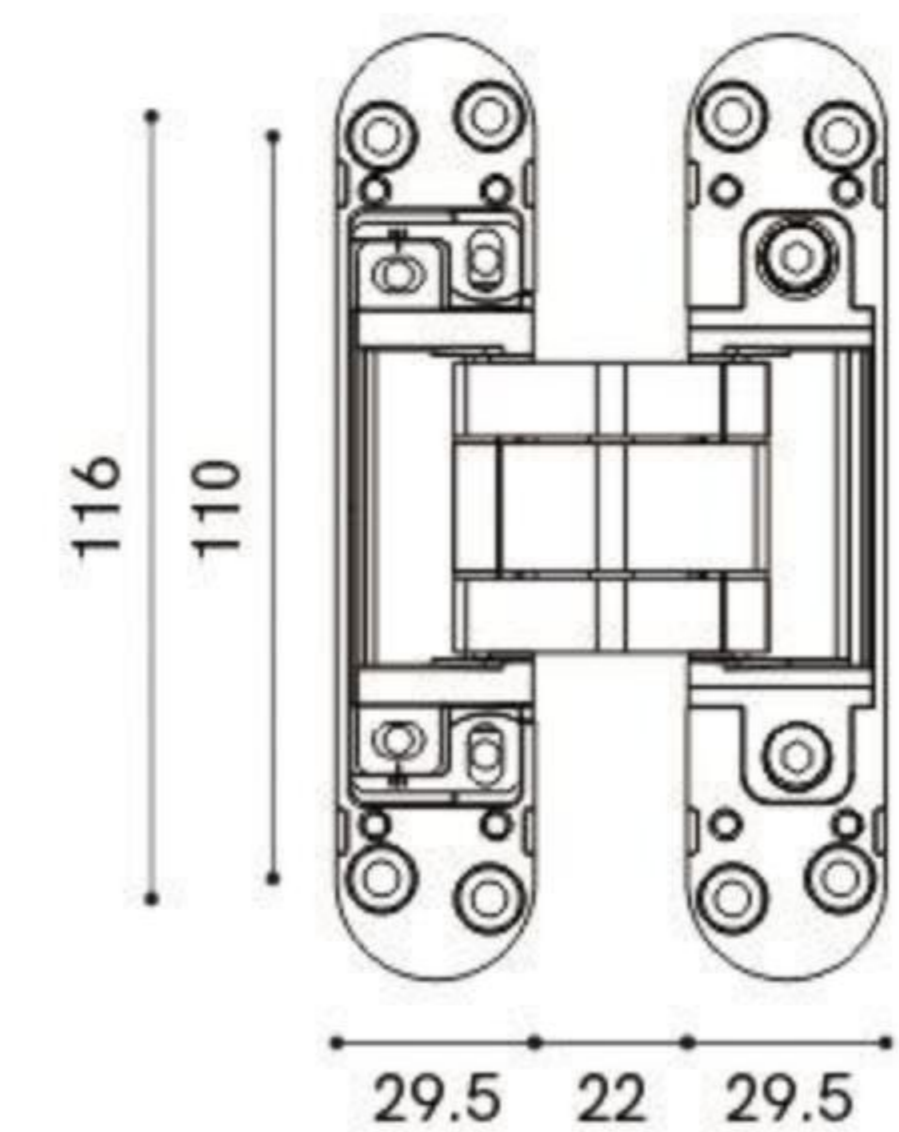
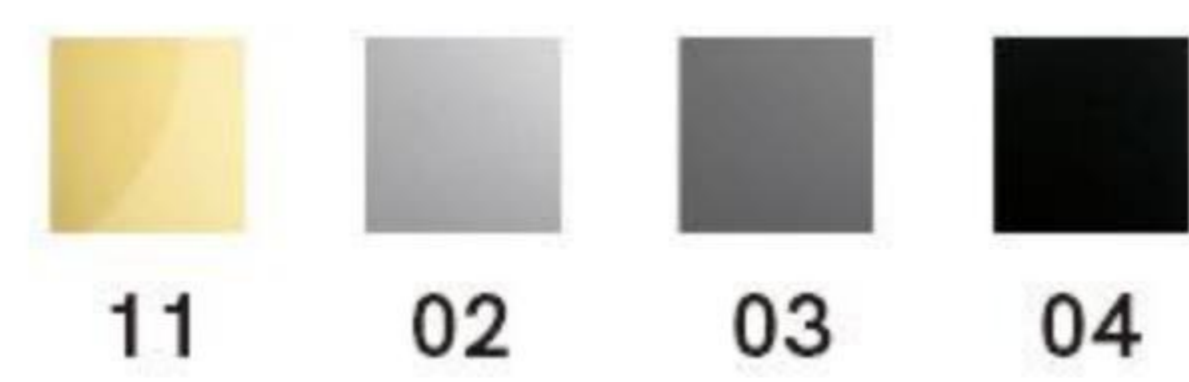

三维可调隐藏铰链

3W-6855



Finish Options
可选表面处理

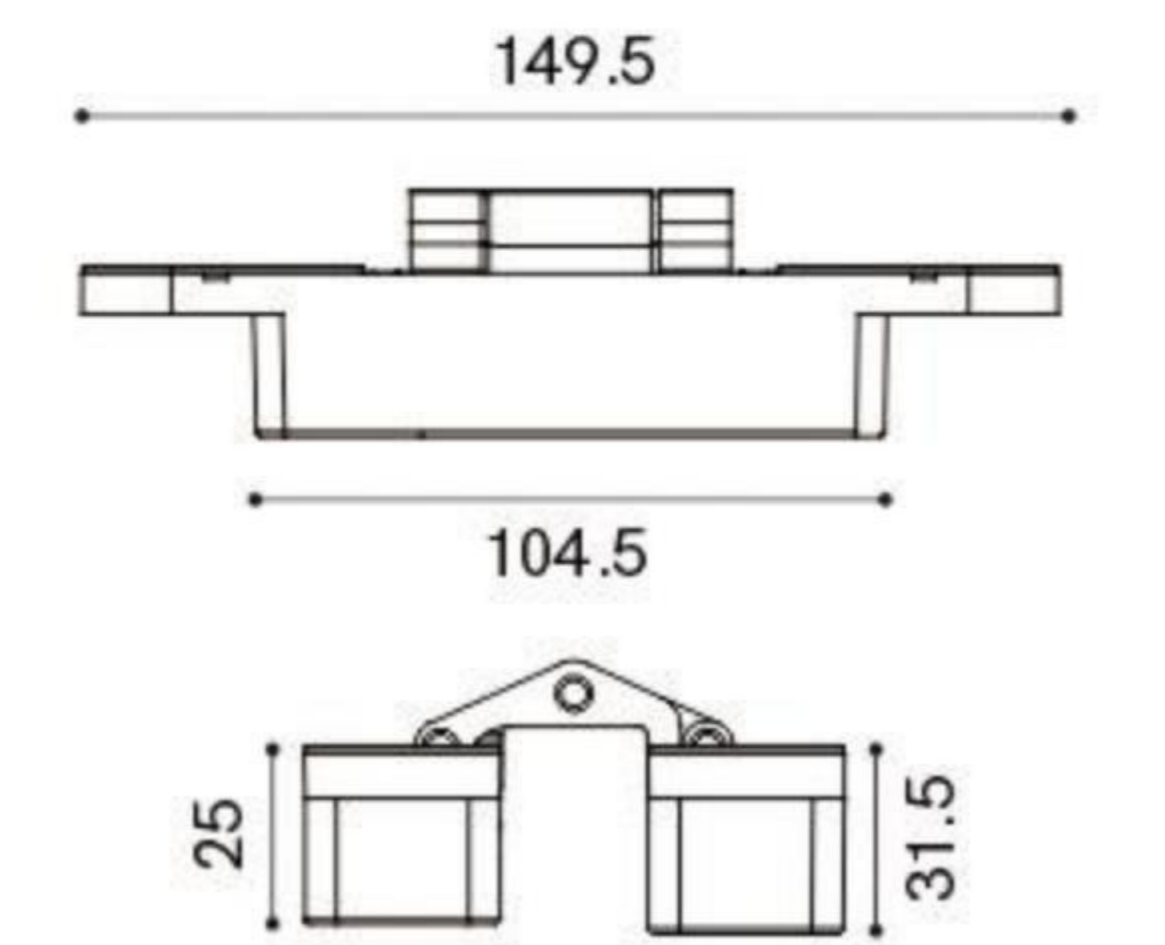
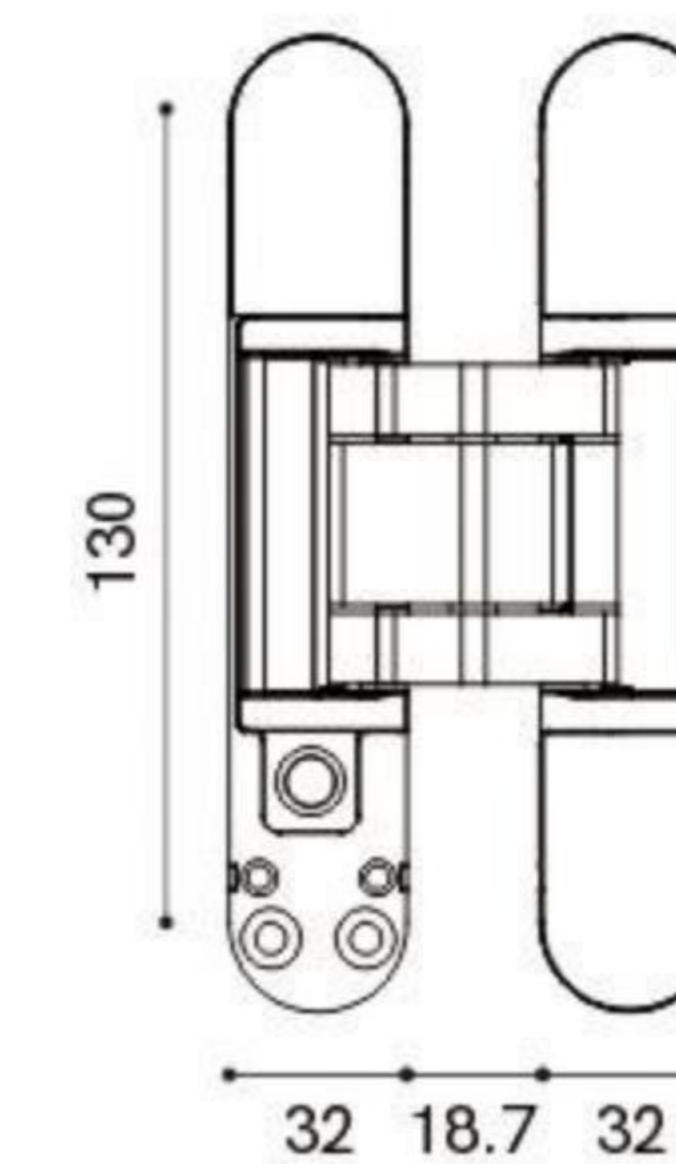
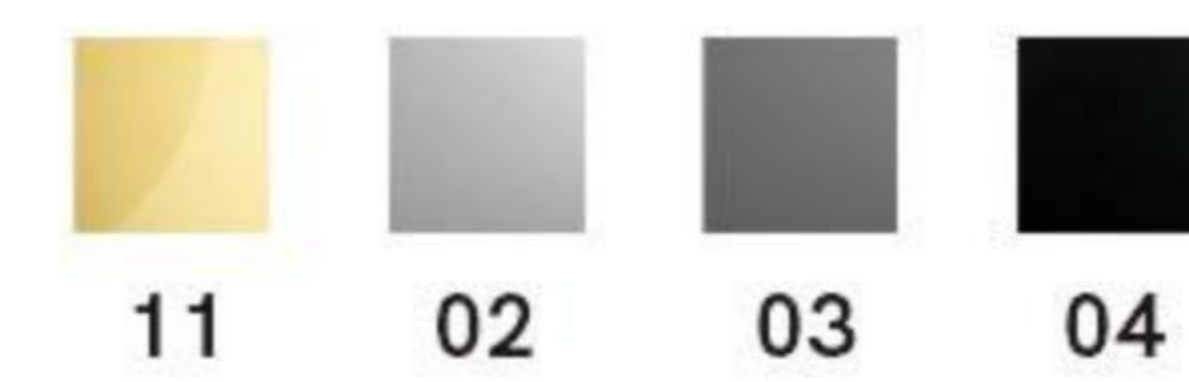

三维可调隐藏铰链

3W-80



Finish Options
可选表面处理

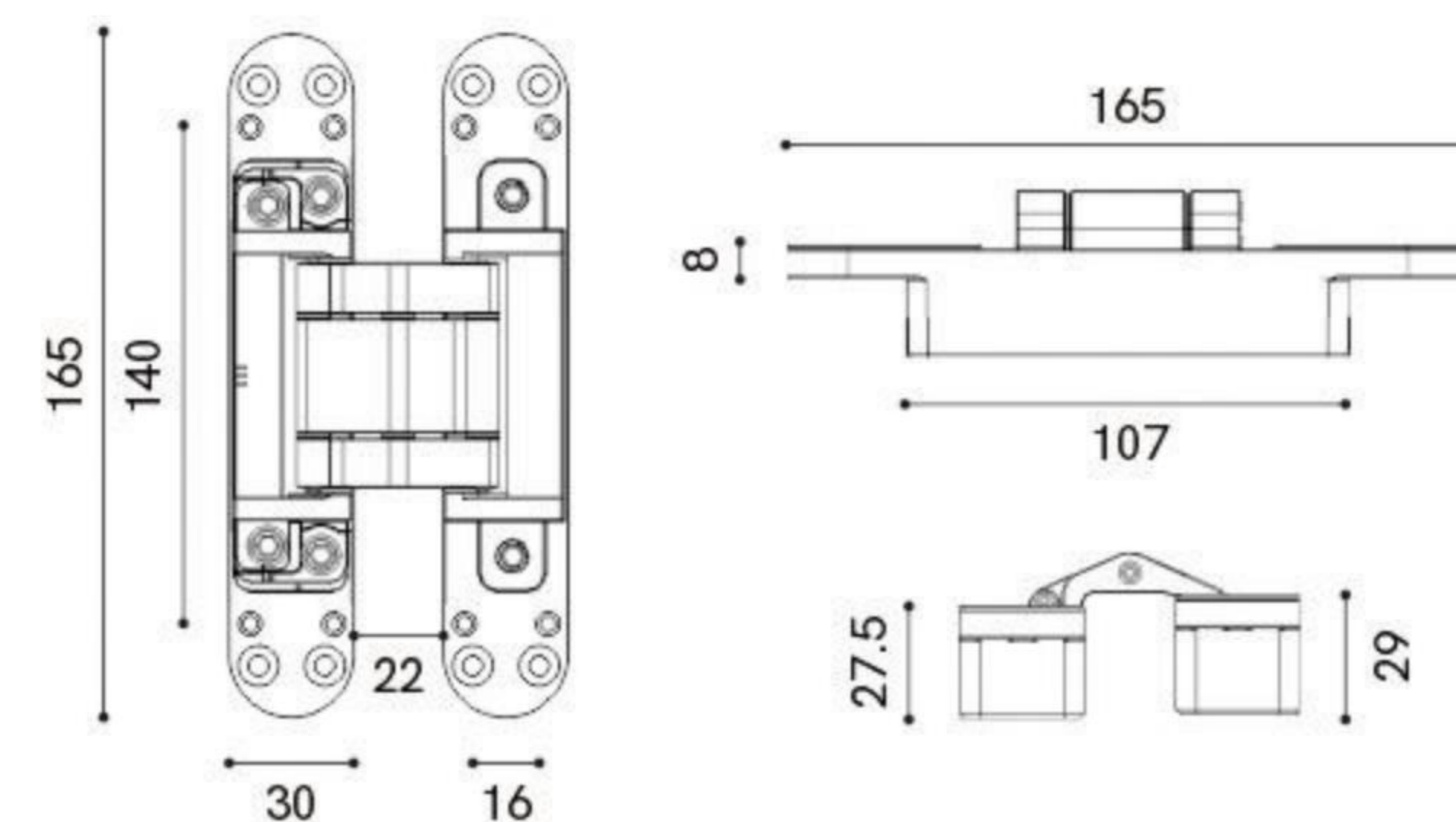
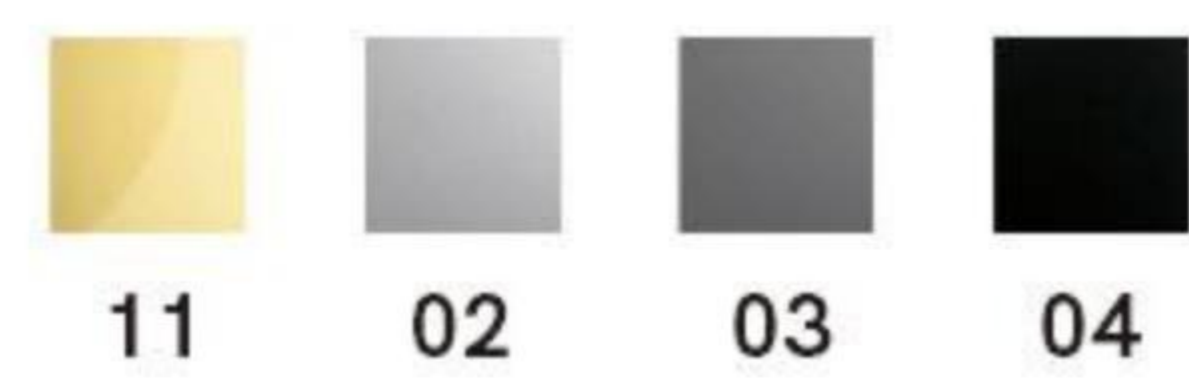

三维可调隐藏铰链

3W-100



Finish Options
可选表面处理

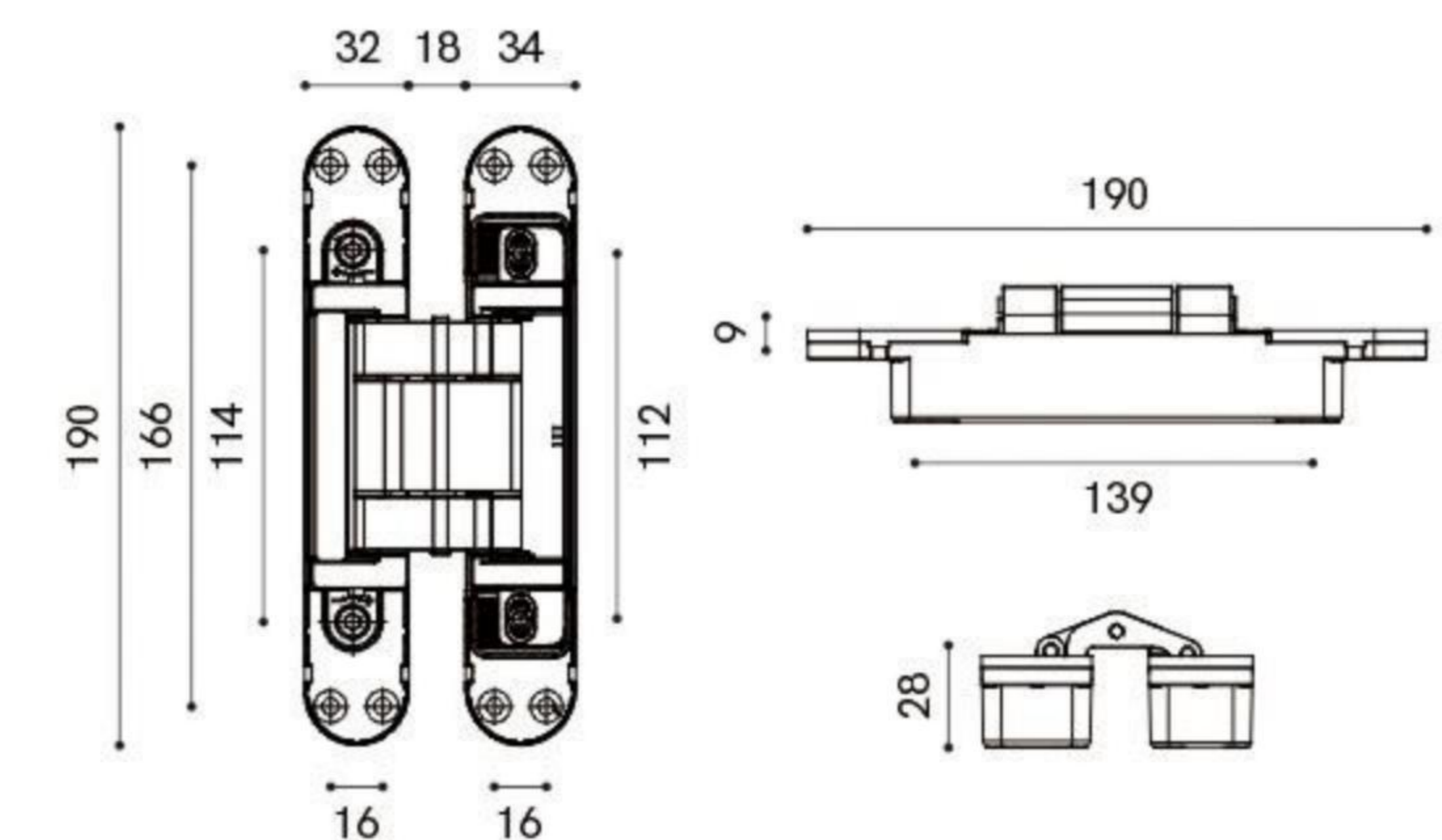
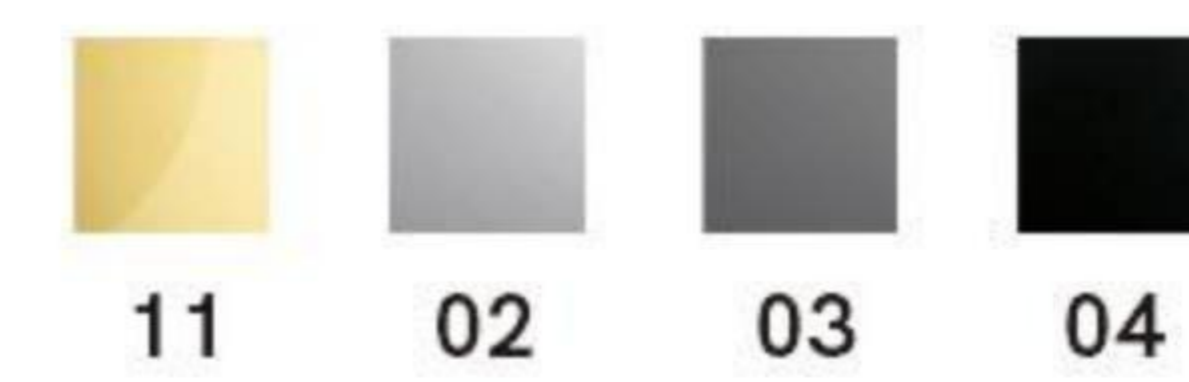

静音缓冲液压合页

—
BL



Finish Options
可选表面处理

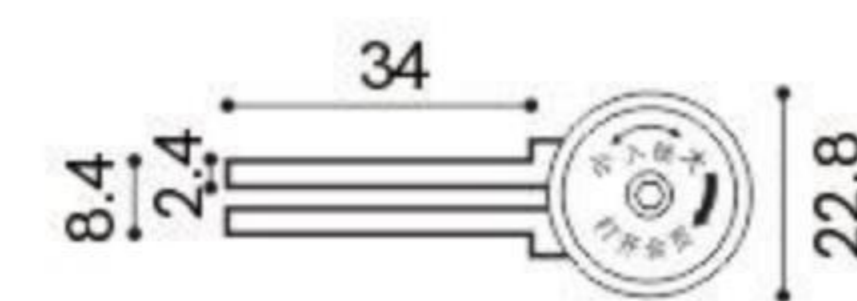
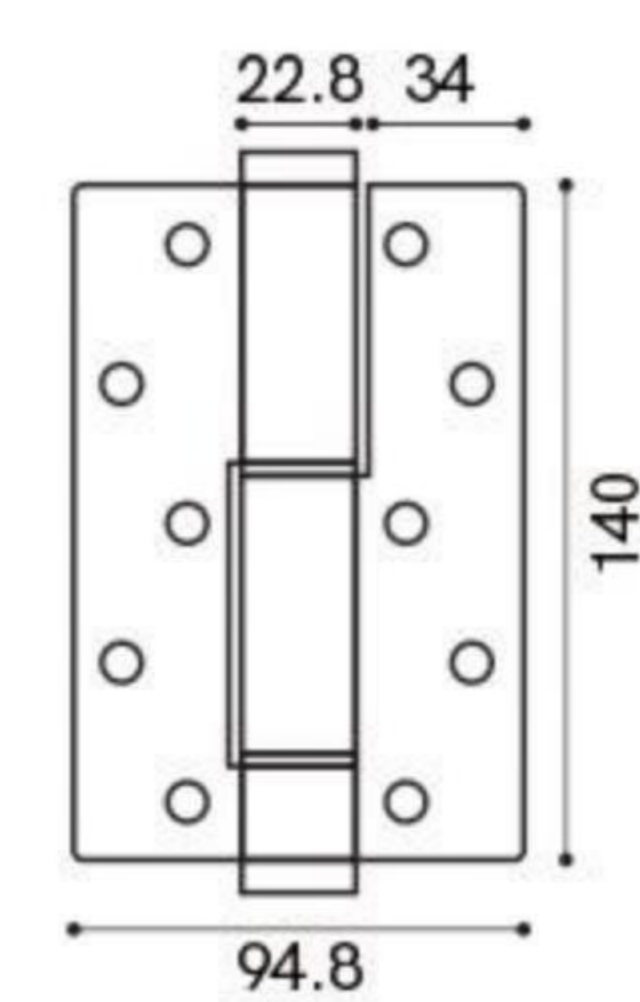
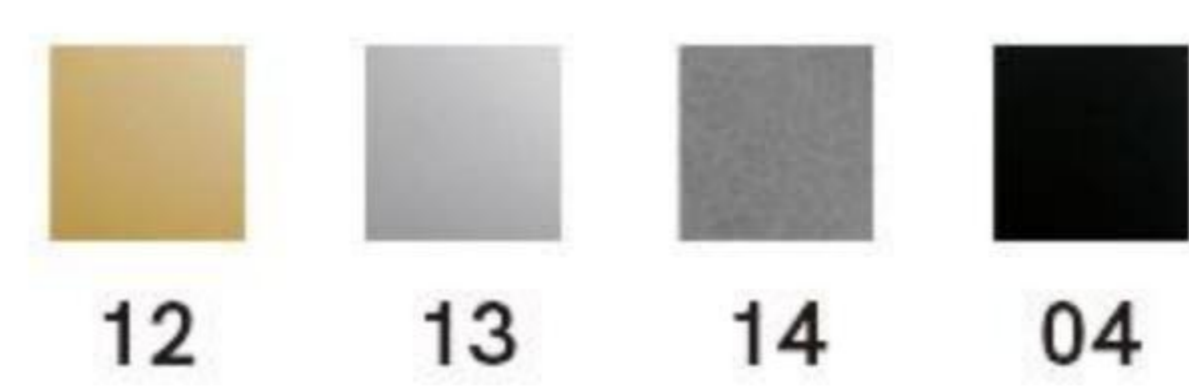

静音缓冲液压合页

AL

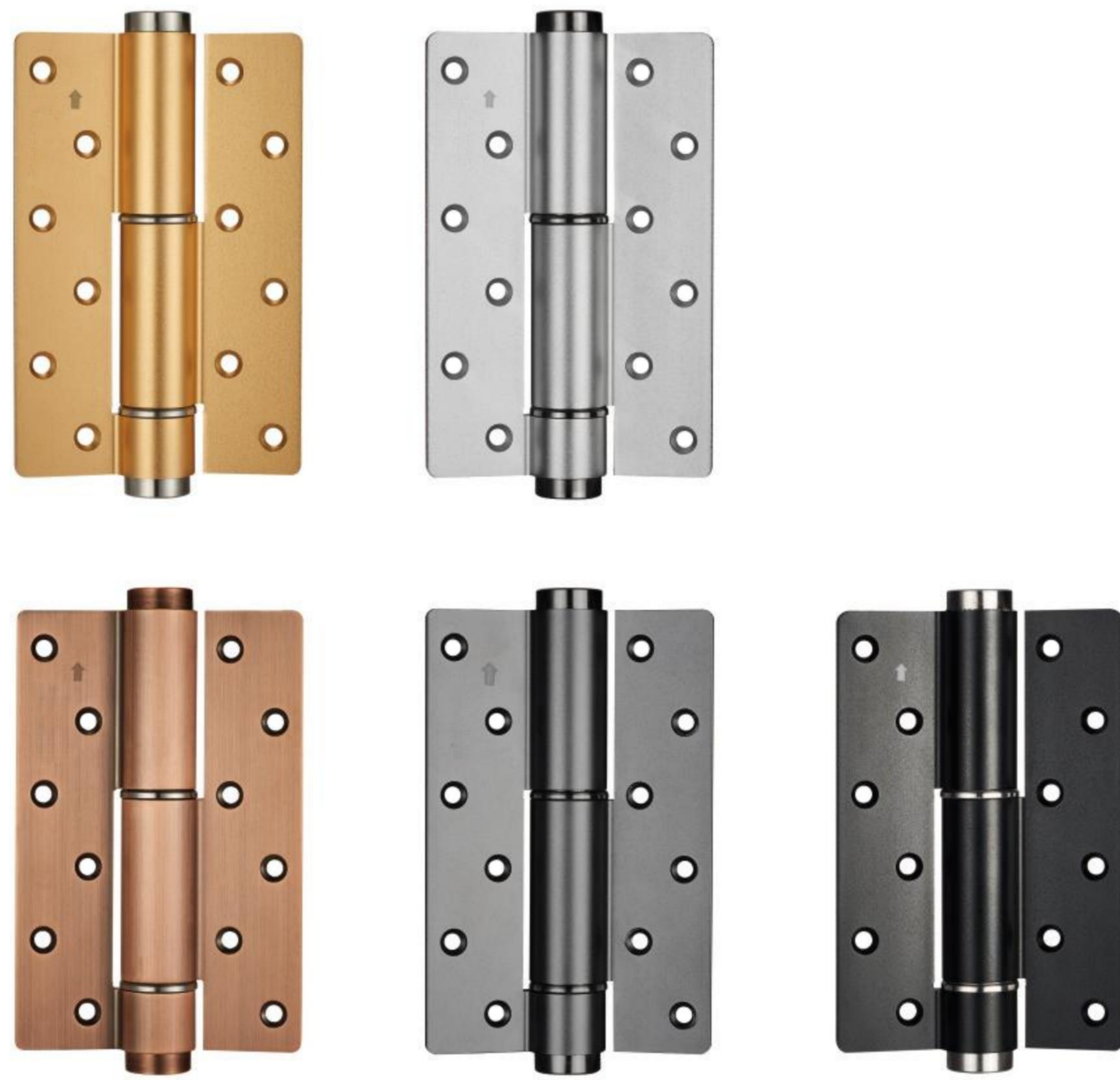

Finish Options
可选表面处理

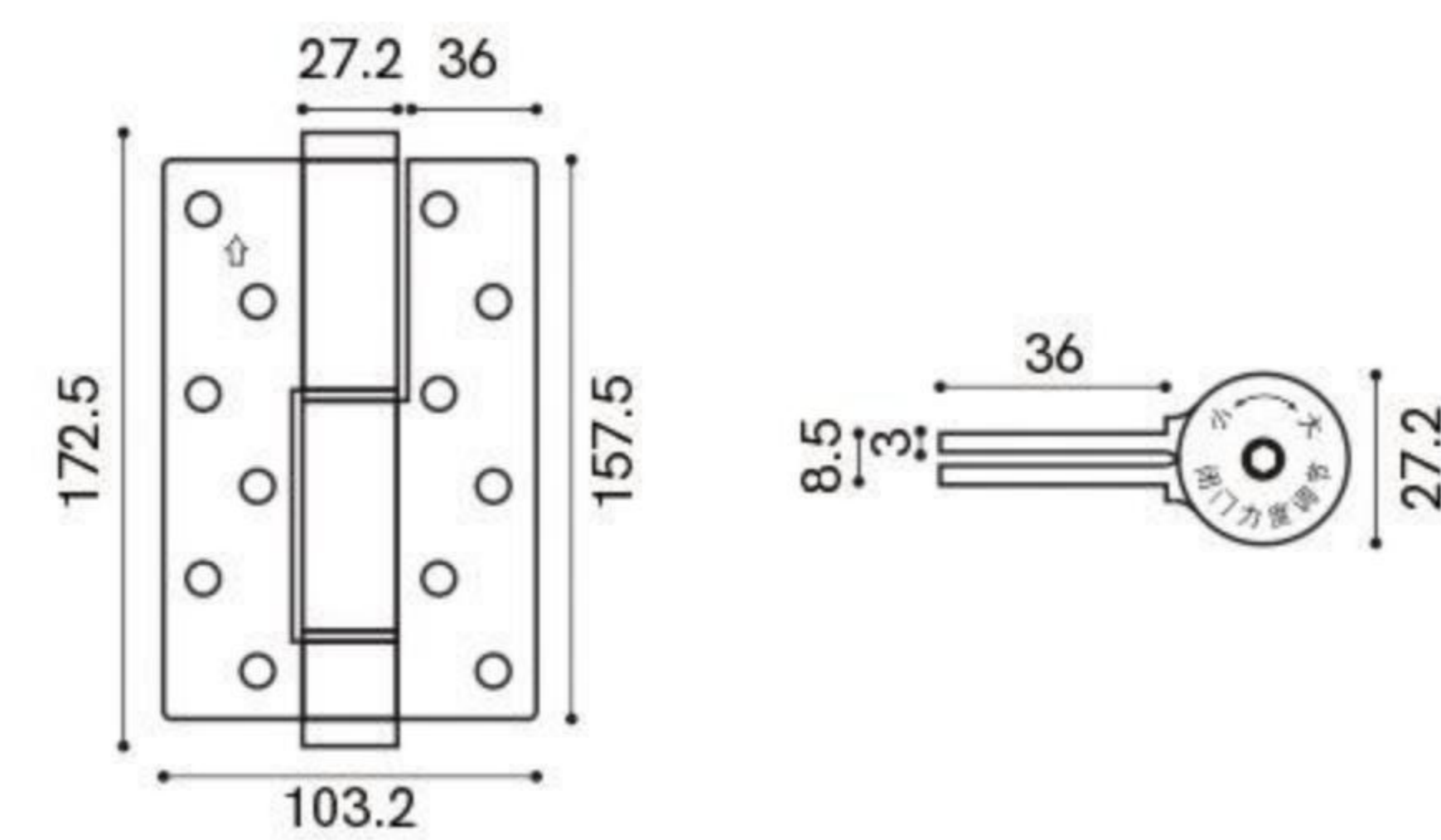

SILENT BUFFER
HYDRAULIC HINGE



静音防风门吸

BK1006



Finish Options
可选表面处理

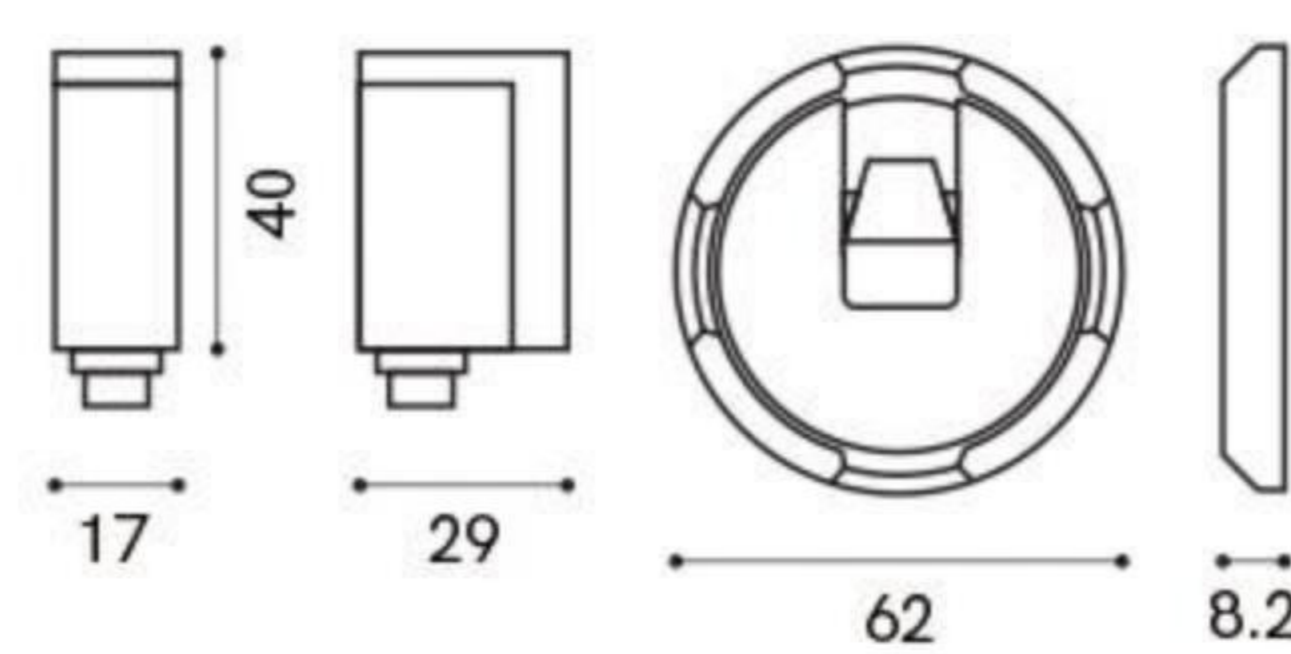
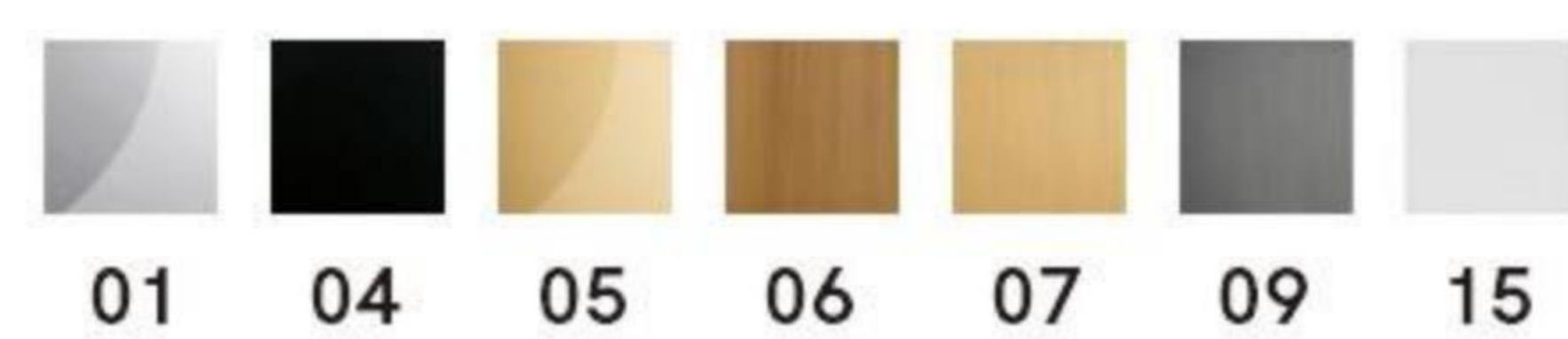

QUIET AND WINDPROOF
DOOR STOPPER

静音防风门吸

一推即锁 再推解锁



锁止防风



一推锁止



减震静音



静音防风门吸

BK1000



Finish Options
可选表面处理

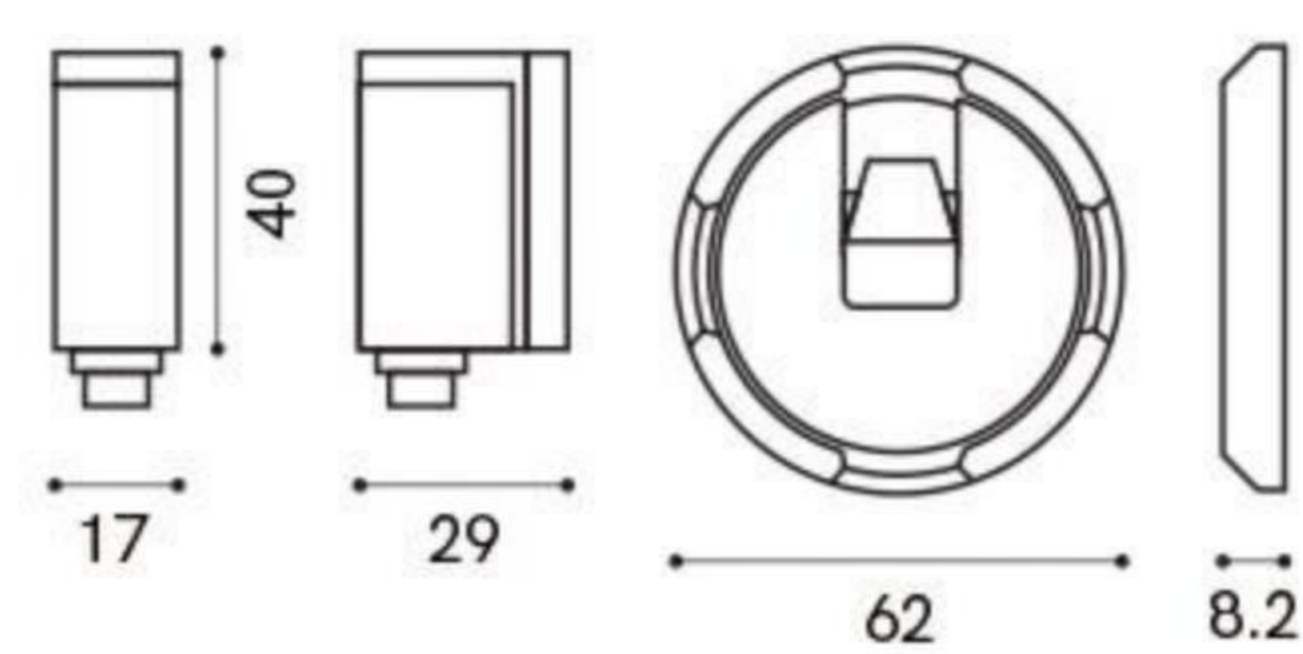
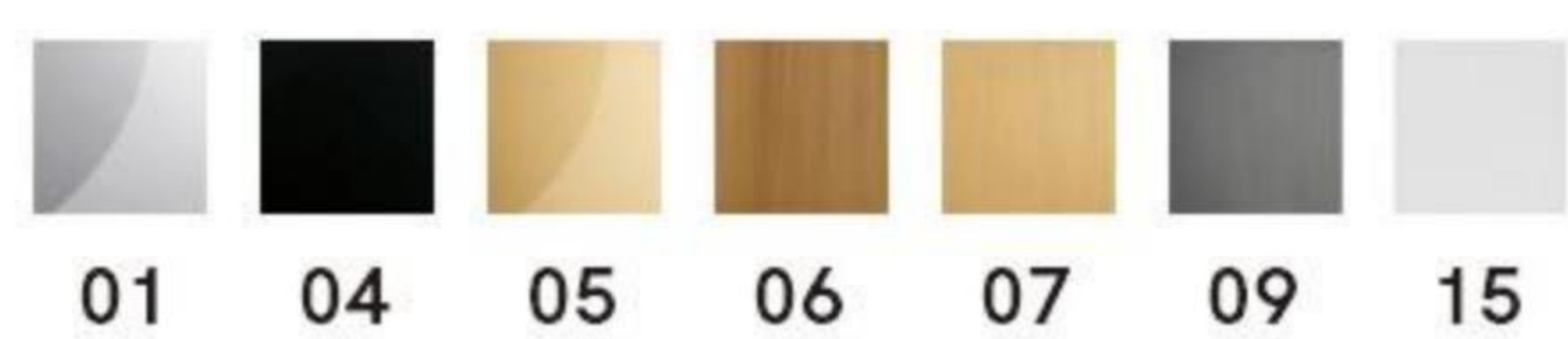

QUIET AND WINDPROOF
DOOR STOPPER

静音防风门吸

一推即锁 再推解锁



锁止防风



一推锁止



减震静音



隐形地吸

BK1003



Finish Options
可选表面处理

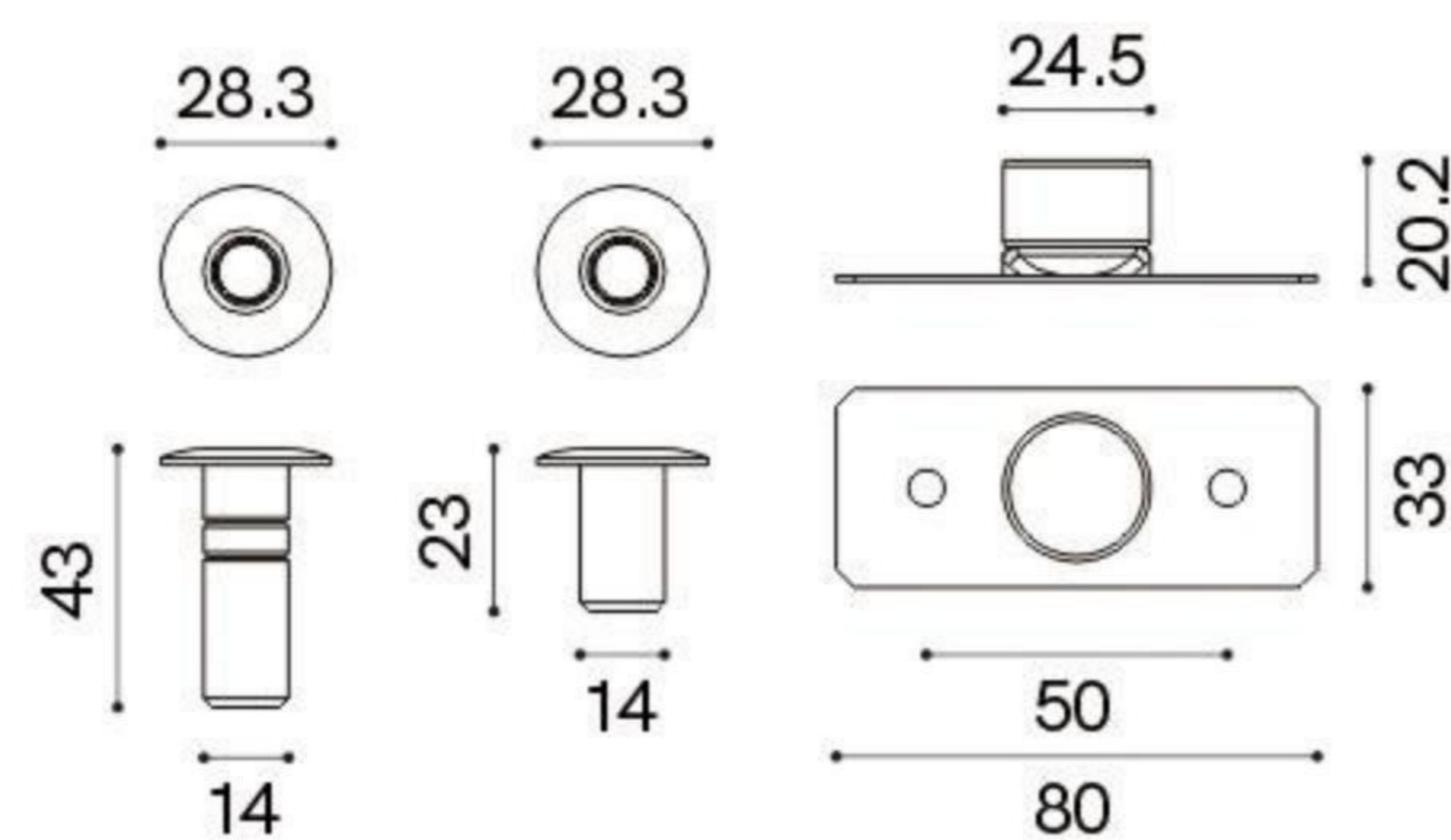
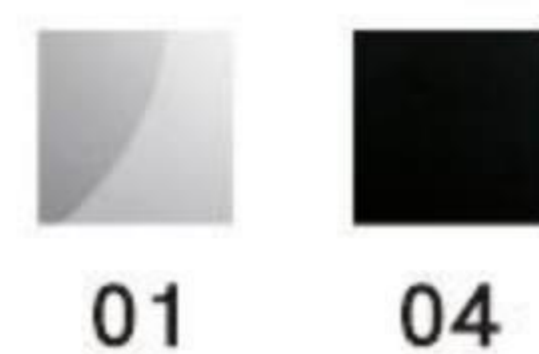

真·隐形地吸

露出地面的高度仅仅为3mm

不占空间 | 不会踢脚 | 吸力强劲 | 强力防风

INVISIBLE
GROUND



静音防风门吸

BK999



Finish Options
可选表面处理

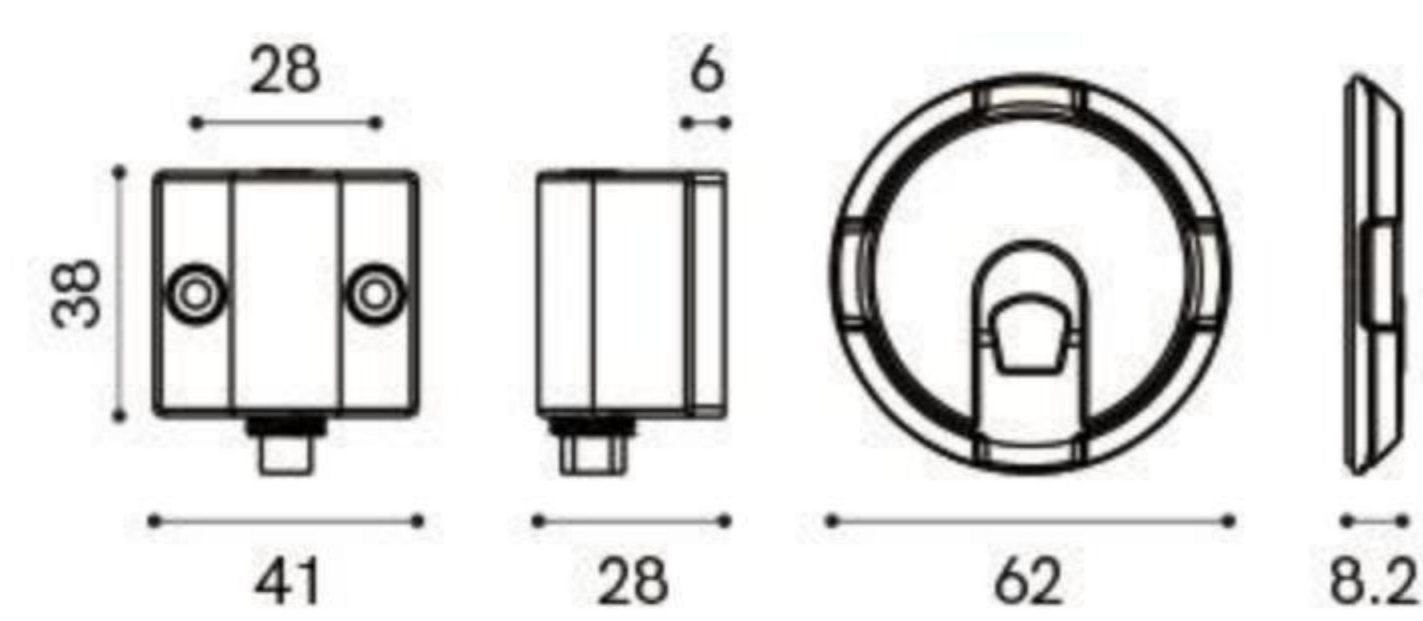
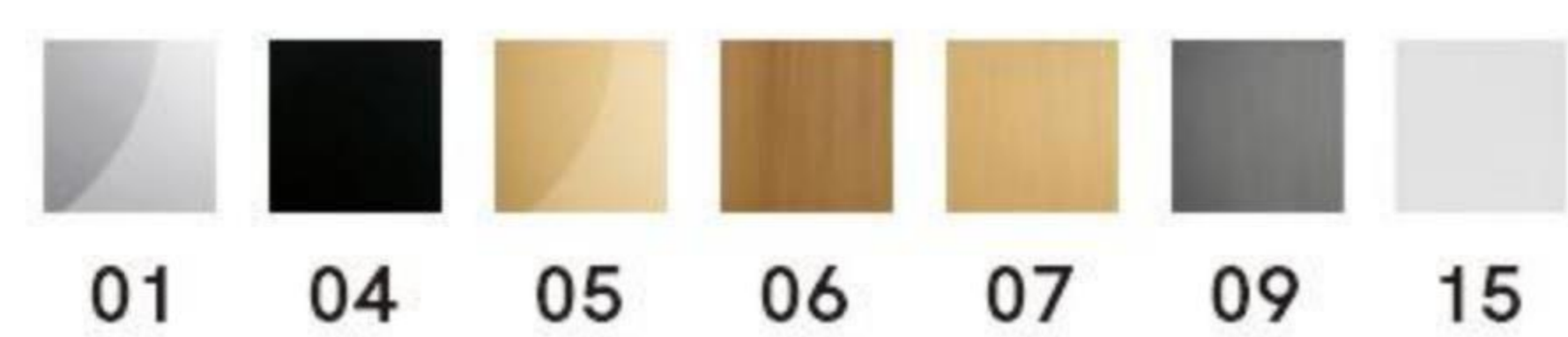

QUIET AND WINDPROOF
DOOR STOPPER

一推即锁
再推解锁

静音防风门吸



静音防风门吸

BK1002



Finish Options
可选表面处理

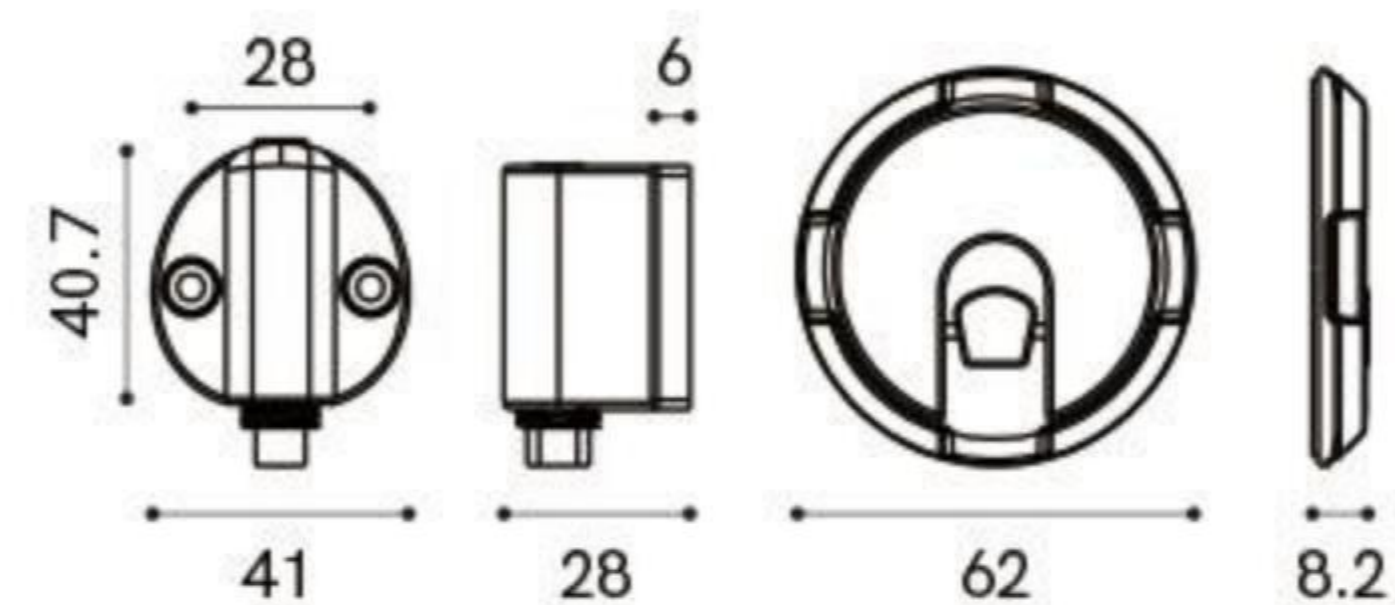
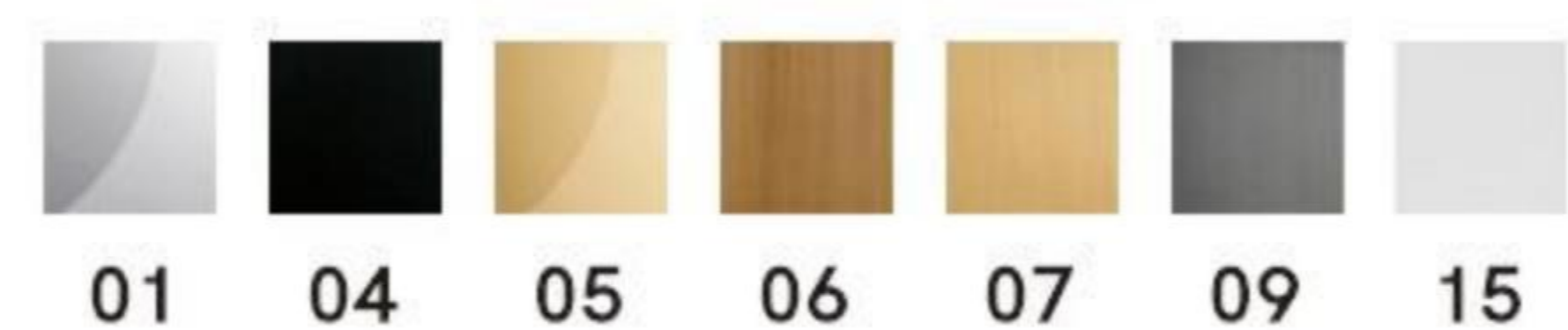

静音防风门吸

BK1001



Finish Options
可选表面处理

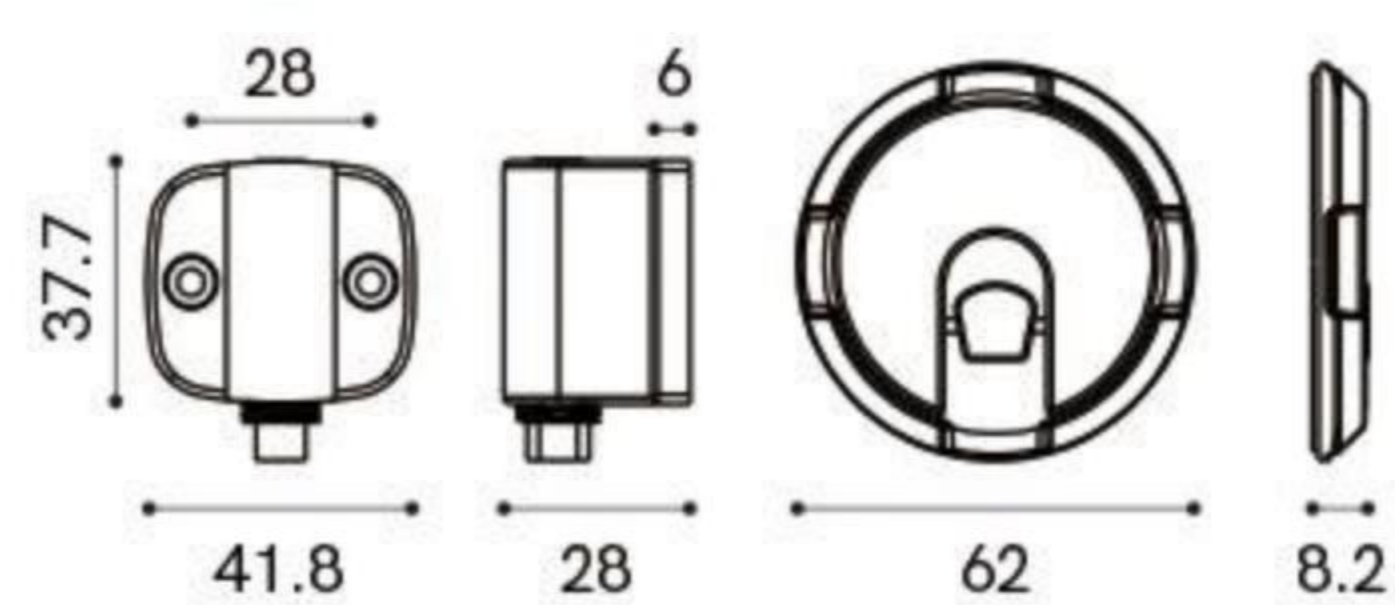
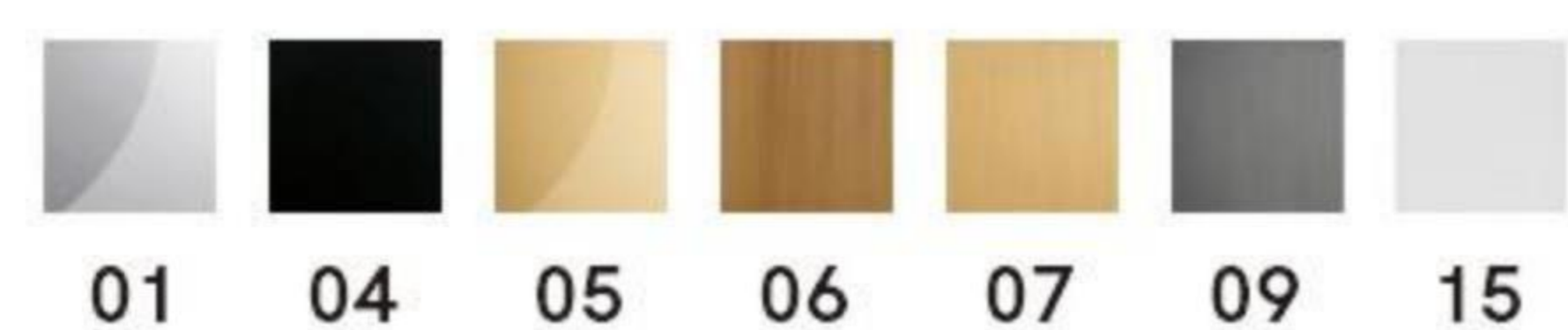

QUIET AND WINDPROOF
DOOR STOPPER



锁止防风 一推锁止 减震静音

